

# OUTDOOR COLLECTION

FUNCTIONAL ART FOR FUNCTIONAL FITNESS



 myequilibria  
Augmented Wellness Design









# Index.

Our Philosophy .....	010
Wellness & Lifestyle .....	012
Benefits of Outdoor Training.....	014
Design & Art .....	016
Design & Science .....	018
Products .....	020
MyTree .....	022
MyAccessories .....	040
Functional Training .....	074
MyBeast .....	076
Sculpture & Fitness .....	104
Mysle .....	106
MyCali Pro .....	120
Technology .....	136
MyEquilibria App .....	138
Awards & Nominations .....	148
Sales Segments .....	150
Partnerships .....	166
Materials .....	172
Safety EU & US .....	180
Who We Are .....	182
Locations .....	184
Offices & Distributors .....	186



Functional Art  
for  
Functional Fitness.





## Phylosophy.

MyEquilibria has its roots in the link between nature and human innovation. Our products represent the evolution of outdoor fitness, characterized by a unique design and cutting-edge production technologies and focused on eco-sustainability.

*MyEquilibria pone le sue radici sul legame tra il mondo naturale e innovazione umana. I nostri prodotti rappresentano l'evoluzione dell'outdoor fitness, caratterizzata da un design unico, da tecnologie produttive all'avanguardia e sensibile all'ecosistema.*





## Wellness & Lifestyle.

Wellness is not only about staying in shape. It's also about achieving a state of physical, mental and spiritual well-being that allows you to achieve your goals, stay healthy, and lead a more engaging, more satisfying, and more harmonious life.

*Wellness non vuol dire soltanto forma fisica, significa anche conquistare quel benessere psichico e spirituale che permette di raggiungere i propri obiettivi, mantenersi sani, condurre una vita più piena, ricca di soddisfazioni e armoniosa.*



## Benefits of outdoor training.

Regular exercise and contact with nature is an easily-accessible, always-available form of preventive and restorative medicine.

*L'attività fisica regolare e il contatto con la natura sono rimedi terapeutici sempre disponibili, per prevenire e curare molte sintomatologie.*



**Reduced Anxiety and Depression**



**Decreased Stress**

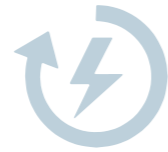

**Increased Energy**



**Increased Immunity**



**50% Lower Risk of Diabetes**



**Increased Vitamin D**



**Increased Weight Loss**



**Reduced Symptoms of A.d.d.**

*\*Benefits are commonly known and accepted by the medical and fitness communities based on numerous studies, reports and research. This is not to replace medical care or treatment. Speak with your doctor prior to making any lifestyle or fitness changes.*

*\*I benefici vengono generalmente riconosciuti ed accettati dalla comunità medica e legata al fitness, basandosi su numerosi studi, report e ricerche. Queste non pretendono di sostituire cure o trattamenti medici. Parlate con il vostro medico prima di effettuare ogni cambiamento nelle abitudini di allenamento o nella vita di tutti i giorni.*







## Design & Art.

The concepts of the outdoor workout and art have coexisted in parallel realities for centuries.

For the first time in history, wellness has brought together cutting-edge exercise equipment and the awe-inspiring quality of art and made them function in perfect unison.

Every curve has been engineered for maximized biomechanics and optimized workout results.

Every exercise session has been selected and developed under the close supervision of the world's most demanding trainers and engineers.

*Attività fisica all'aperto e arte sono due concetti che convivono da secoli in realtà parallele.*

*Oggi, per la prima volta nella storia, il benessere propone soluzioni avanguardistiche in cui il design di attrezzature sportive e l'arte alla sua massima espressione convergono creando un'armonia perfetta.*

*Ogni linea è stata studiata per ottenere massimi livelli di biomeccanica e ottimizzare le prestazioni fisiche.*

*Ogni sessione di allenamento è stata scelta e sviluppata sotto la stretta supervisione di trainer e progettisti tra i più esigenti e preparati a livello mondiale.*



## Design & Science.

MyEquilibria design and engineering teams, have gone to extraordinary lengths to ensure the maximized safety and durability of each installation, without detracting from its elegance and clean, minimalistic look and feel.

Luxuriously smooth concrete surfaces seamlessly meet steel, aluminium and wood components, guaranteeing maximum stability, safety and performance.

*I team di designer e progettisti di MyEquilibria si sono impegnati oltremisura per garantire il massimo della sicurezza e della durabilità di ciascuna attrezzatura, senza nulla togliere all'estetica elegante e senza rinunciare a un look pulito e minimalista apprezzabile anche al tatto.*

*Superfici di cemento lisce, dalla levigatezza raffinata, si fondono naturalmente con componenti di acciaio, alluminio e legno garantendo stabilità, sicurezza e performance ai massimi livelli.*



## Products.

We have worked hand-in-hand with designers, professional trainers and a team of industrial engineers to create installations that are secure and technically accessible to all levels of preparation.

When you exercise, you follow natural body movements that make you more athletic and healthier, not just more muscular.

*Abbiamo lavorato in stretta collaborazione con designer, grandi esperti di fitness, trainer, trendsetter del mondo del wellness e ingegneri per creare attrezzature sicure e tecnicamente accessibili, a qualunque livello di preparazione.*

*Quando fai esercizio, il corpo esegue dei movimenti naturali che ti portano ad essere piu' atletico e sano, non solo piu muscoloso.*





# MyTree.

MyTree strives to shape the future of outdoor wellness and challenges every convention surrounding fitness equipment.

All MyTrees are available in 3-leaves or 6-leaves configuration.

- Engineered around the biomechanics of instinctive training;
- inspired by nature;
- designed featuring the same attention to detail, style and technological sophistication you would expect from a contemporary work of art.

*MyEquilibria intende dare un nuovo futuro all'outdoor wellness lanciando una sfida alla visione tradizionale delle attrezzature per il fitness.*

*Tutti i MyTree sono disponibili nella versione a 3 foglie o 6 foglie.*

- *Progettata nel rispetto della biomeccanica dell'allenamento intuitivo;*
- *ispirata alla natura;*
- *realizzata con la stessa attenzione al dettaglio, allo stile e all'innovazione tecnologica che potremmo trovare in un'opera d'arte contemporanea.*







National Museum of Singapore  
Museum Negara  
Museum Negara

# Full Tree.

DESIGNED BY VITO DI BARI

Parallel Bars

Pull-ups Bar

Rings Set

Suspension Training Hooks

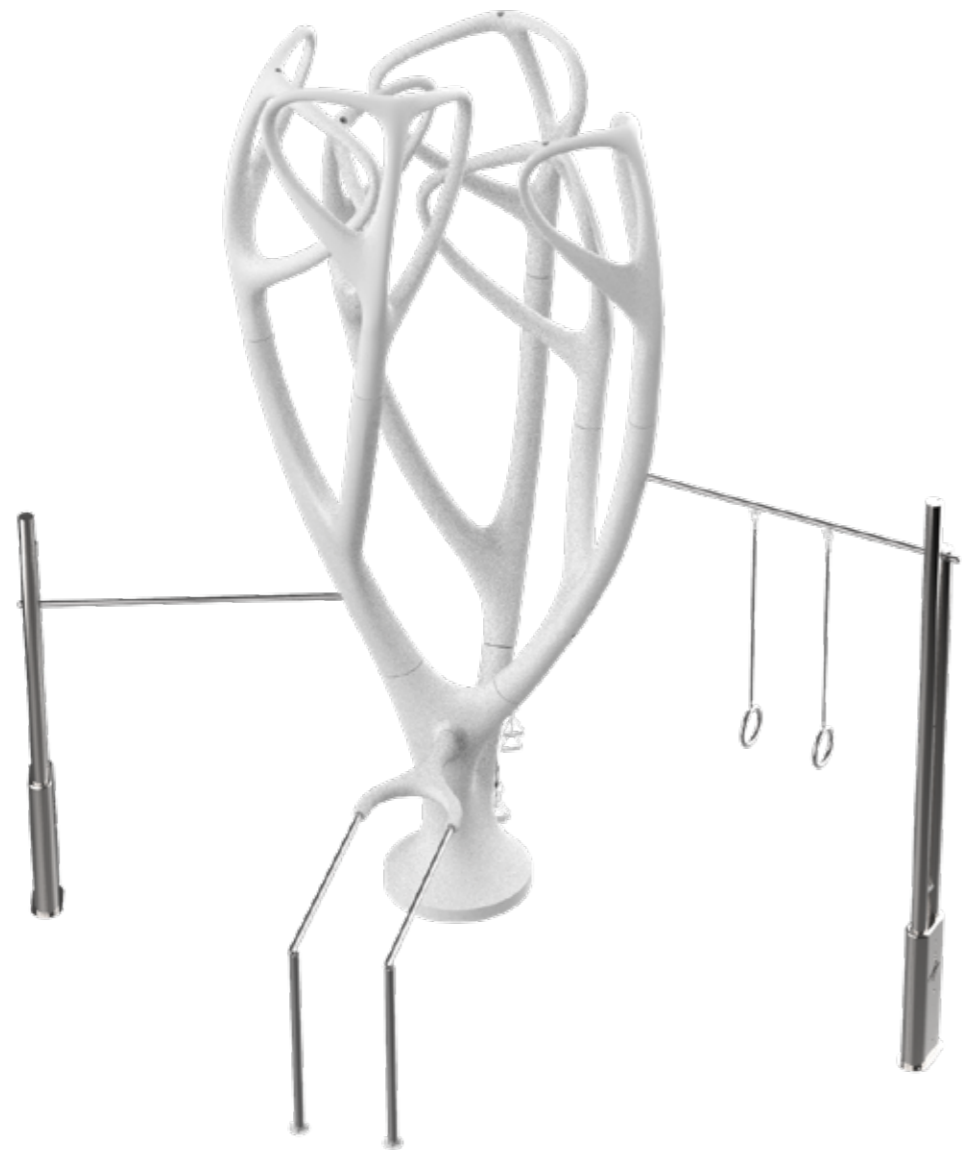

Full Tree combines most popular types of MyEquilibria trees to offer a complete outdoor gym, designed to challenge all major muscle groups. The 6 MyEquilibria leaves give a unique and natural design to the structure.

*Il Full Tree unisce e combina le tipologie più particolari degli alberi MyEquilibria per offrire una palestra outdoor completa in grado di potenziare tutti i maggiori gruppi muscolari. Le 6 foglie MyEquilibria trasmettono un design unico e naturale alla struttura.*

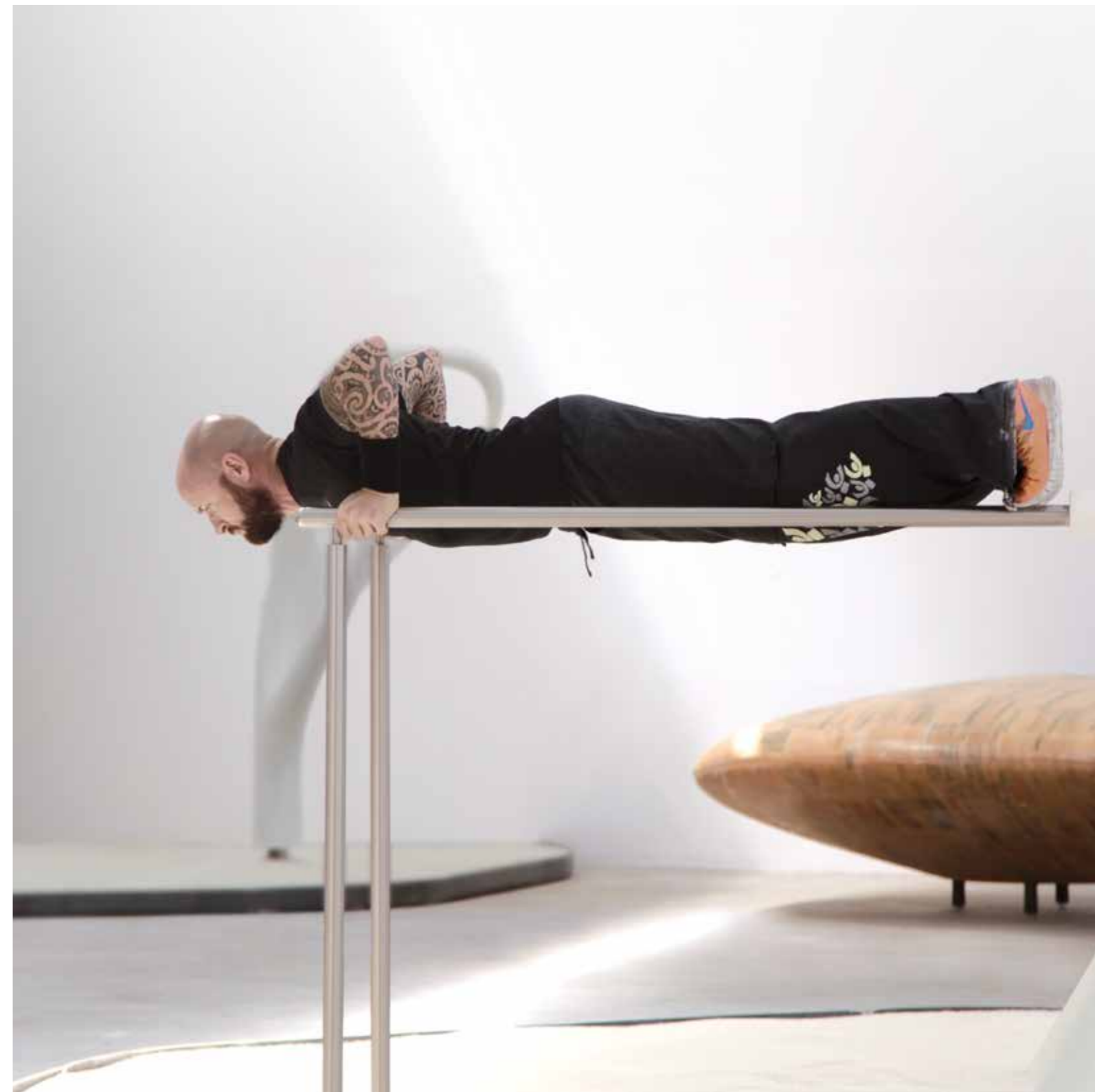



# Rings Tree.

DESIGNED BY VITO DI BARI

High Rings Set

Medium Rings Set

Low Rings Set



Rings training requires only a few movements to effectively build muscle size and definition in record time. The combination of three ring-stages, hooked at different heights, blends perfectly with the 3-leaf structure.

*L'allenamento agli anelli richiede solo pochi movimenti per costruire efficacemente le dimensioni dei muscoli e definirli in tempi record. La combinazione di tre ring-stage, collocati a diverse altezze, si fonde perfettamente con la struttura a 3 foglie.*

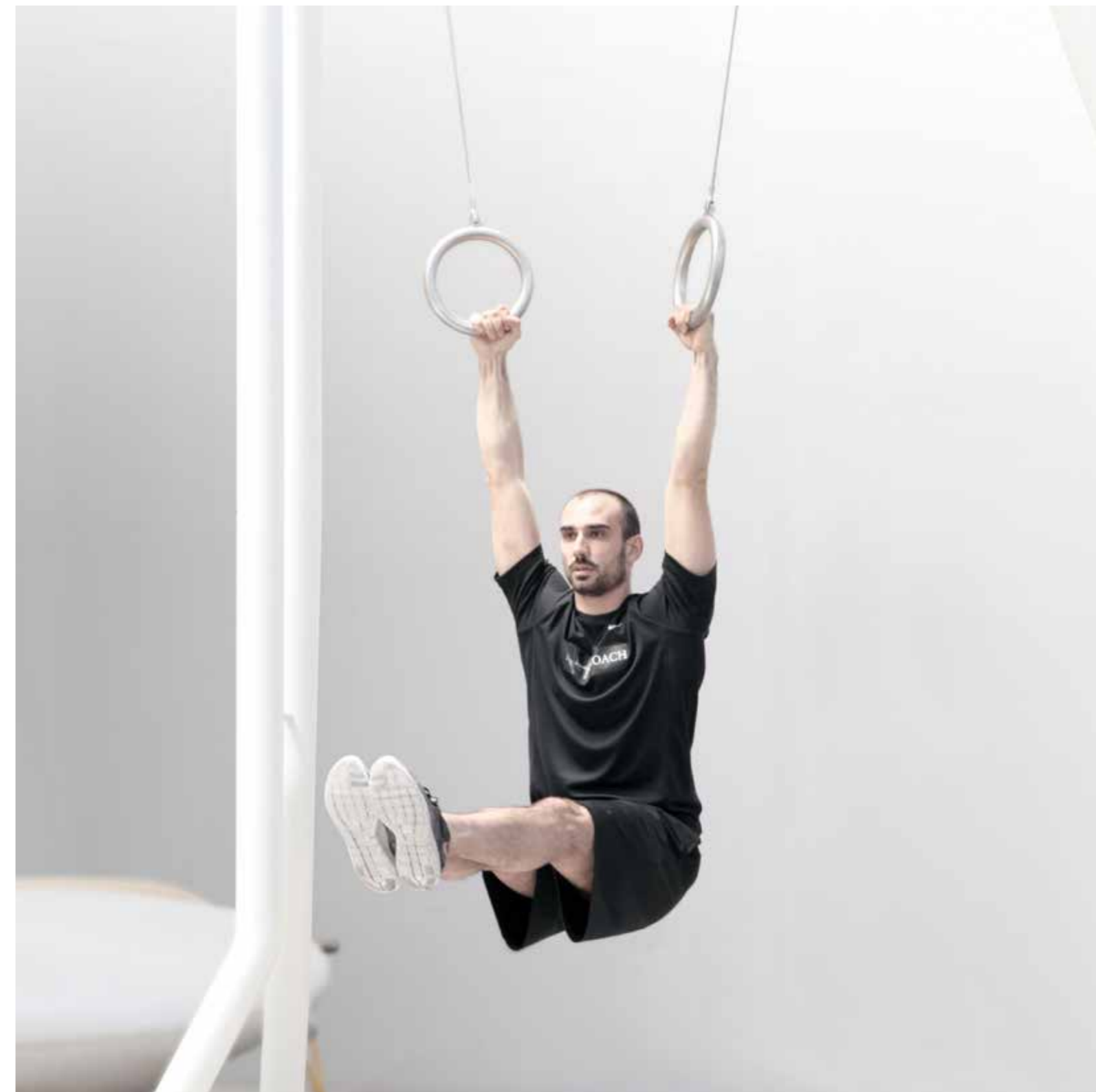

# Unparalleled Tree.

DESIGNED BY VITO DI BARI

Parallel Bars

High Pull-ups Bar

Low Pull-ups Bar

Suspension Training Hooks



Pull-ups Bars and Parallel Bars are the ultimate exercise to engage your core and strengthen your back, chest and arms. This configuration aims to quickly develop strength, coordination, balance and agility.

*Le parallele e le barre Pull-ups rappresentano l'allenamento definitivo per rafforzare la schiena e far lavorare il tronco, i pettorali e le braccia. Questa configurazione mira a sviluppare rapidamente forza, coordinazione, equilibrio e agilità.*





# Vertical Tree.

DESIGNED BY VITO DI BARI

Climbing Ropes

Suspension Training Hooks

Independent Flag Pole



The Vertical Tree is a proven and versatile workout tool that helps building explosive strength, power, endurance and cardiovascular conditioning and effectively burn fat. The Vertical Tree combines 2 climbing ropes with an independent Flag Pole.

*Il Vertical Tree rappresenta la reinterpretazione innovativa di un attrezzo versatile che aiuta a maturare una forza esplosiva, potenza, resistenza, buone condizioni cardiovascolari e a bruciare efficacemente i grassi. L'albero unisce due corde da arrampicata con un palo verticale indipendente.*



# Zen Tree.

DESIGNED BY VITO DI BARI



Developed for wellness activities that promote focus, relaxation and flexibility, the 3-leaf Zen Tree is a great addition to other outdoor activities and bodyweight installations.

*Sviluppato per le attività fisiche che promuovono la concentrazione, il rilassamento e la flessibilità, lo Zen Tree a tre foglie è il complemento ideale per le altre attività all'aperto e attrezzature per l'outdoor training.*





# Full Tree Functional on platform.

DESIGNED BY VITO DI BARI & ALFREDO TASCA

- Parallel Bars
- Pull-ups Bar
- Rings Set
- Suspension Training Hooks
- Box jump set
- Flat Bench
- Battle Rope
- Rotary Push-ups
- Parallettes
- Sliding Push-ups
- Pistols
- Hooks

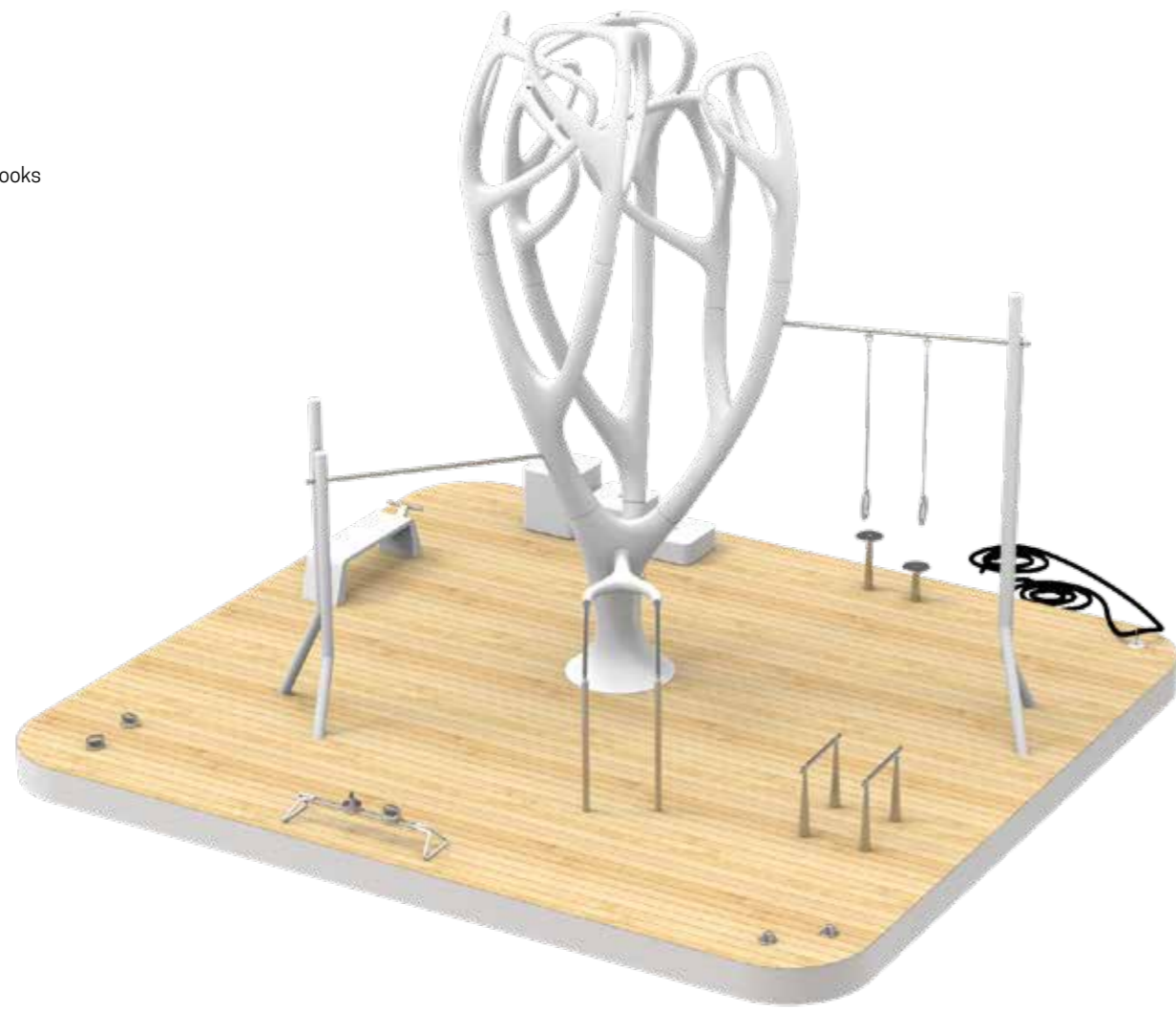

The first complete private gym. With the combination of numerous accessories and designed around the revolutionary Full Tree, this "isle" represents a true challenge for all the major muscle groups. The uniqueness of the platform is in complete harmony with the natural 6-leaf tree structure. These stations comfortably fits up to 24 people.

*La prima palestra privata completa. Con la combinazione di numerosi accessori e progettata attorno al rivoluzionario Full Tree, questa "isola" rappresenta una vera e propria sfida per tutti i gruppi muscolari principali. L'unicità della piattaforma è in completa armonia con la struttura naturale a 6 foglie dell'albero. Possibilità di ospitare fino a 24 persone.*









## MyAccessories.

Our accessories are a seamless continuation of MyEquilibria installations. Naturally, we engineered them by following the same principles of absolute precision and exceptional performance that we used to design our fitness installations.

*I nostri accessori sono la naturale prosecuzione delle attrezzature. Sono stati progettati nel rispetto degli stessi principi di precisione assoluta e di livelli di performance eccezionali seguiti per la realizzazione delle attrezzature MyEquilibria.*







## Ground Hooks.



Thanks to a wide range of tubes featuring various resistance levels and the Easy-Connect Hook System, it is possible to do hundreds of strength training, resistance and coordination exercises.

*Grazie a una grande varietà di elastici con differenti livelli di resistenza e a Easy-Connect-Hook-System, si possono effettuare centinaia di esercizi per migliorare forza, resistenza e coordinazione.*





## Stability Board.



This solid, versatile, premier accessory has quickly gained popularity for balance and functional training, calisthenics and gymnastics for its effectiveness and universality. Also available in a STAND-ALONE version.

*Questo attrezzo versatile si è rapidamente fatto un nome tra gli esperti di allenamento funzionale e di equilibrio, calisthenics e ginnastica grazie alla loro efficacia e universalità.*

*Disponibile anche STAND ALONE.*





## Battle Rope Loop.



A favorite training tool for elite athletes, Special Forces and professional sports teams. Battle Rope is one of the most effective tools to burn fat.

*E' l'attrezzo preferito da grandi atleti, corpi speciali e squadre sportive. Il Battle Rope rappresenta uno degli attrezzi più efficaci per consumare i grassi.*



## Landmine.



Landmine is the ideal accessory to develop strength. 360-degree mobility allows users to focus on any individual muscle group while different plates can be added to the outrigger for the desired amount of weight resistance.

*Il Landmine è l'accessorio ideale per sviluppare la forza. La mobilità a 360 gradi consente agli utenti di concentrarsi su ogni singolo gruppo muscolare, mentre diverse piastre possono essere aggiunte, per raggiungere la quantità desiderata di resistenza.*





# Pistols.



The perfect way to train for balance, allowing development of flexibility, coordination and endurance while challenging commonly overlooked and often weakened stabilizers and assisting muscles.

*Il modo ideale per lavorare sull'equilibrio e consente di sviluppare flessibilità, coordinazione e resistenza; coinvolgono anche i muscoli stabilizzatori secondari che, venendo in genere ignorati, spesso sono i più deboli.*





## Parallettes.



These solid, versatile, premier accessories have quickly gained popularity for functional training, calisthenics and gymnastics because of its effectiveness and universality.

*Questi attrezzi versatili si sono rapidamente fatti un nome tra gli esperti di allenamento funzionale, calisthenics e ginnastica grazie alla loro efficacia e universalità.*





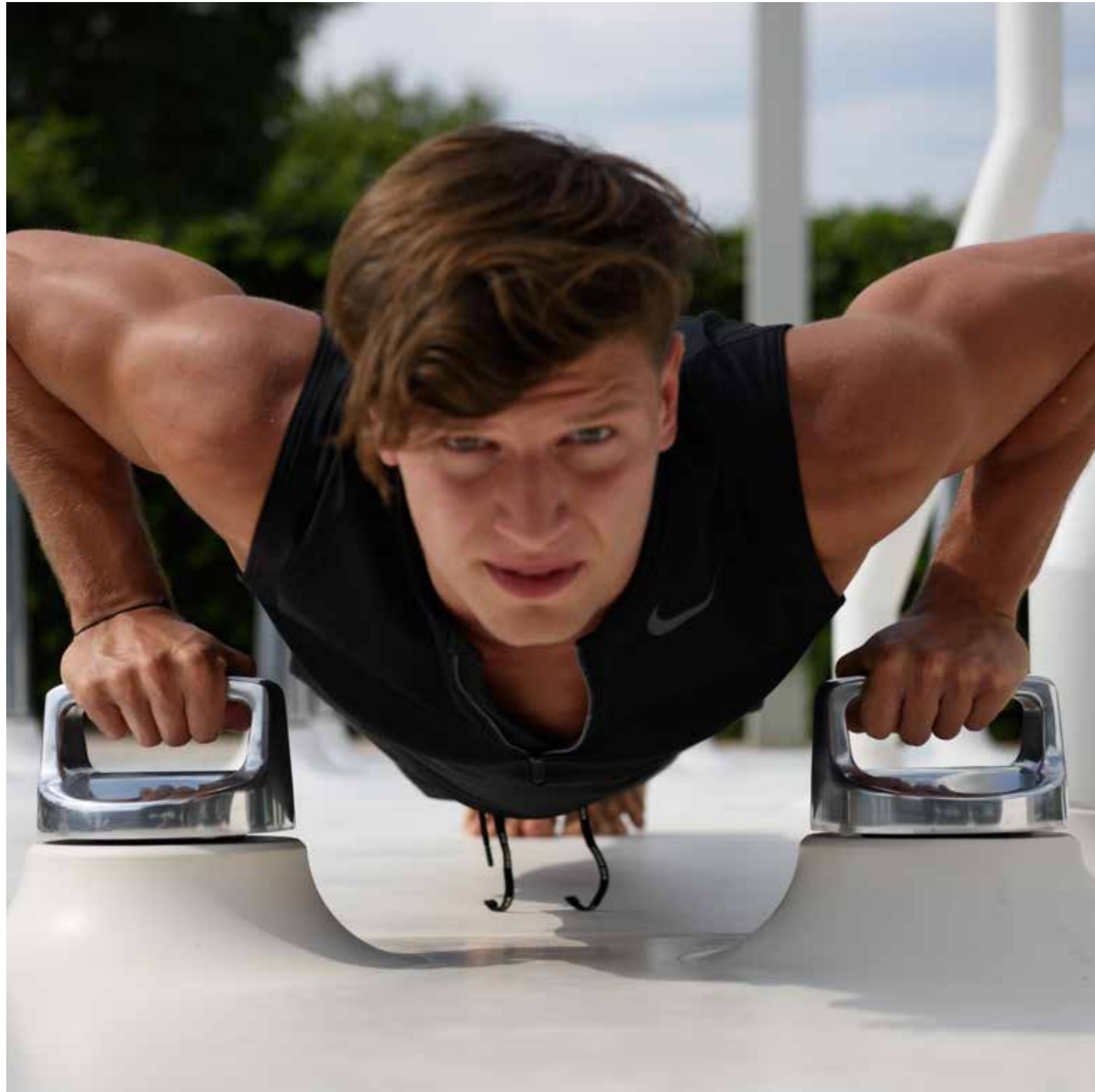

## Rotary Push-ups.



Rotary Push-ups allows an enhanced workout routine and gets the most out of the push-up exercise, challenging muscles even further. At the same time smoothly rotating handles help to reduce strain on wrists. Also available in a STAND-ALONE version.

*Le maniglie Rotary Push-ups consentono di svolgere un super allenamento traendo il massimo beneficio dagli esercizi di push-up e facendo lavorare i muscoli ancora più a fondo. Al tempo stesso, grazie alla fluidità di rotazione di queste maniglie, lo sforzo sui polsi è ridotto. Disponibili anche STAND ALONE.*

## Fix push-ups.



One of the greatest, simplest, most complete and popular exercise movements for developing some serious upper body strength. Fixed Push-Ups also activates the entire core. Also available in a STAND-ALONE version.

*Uno degli esercizi ginnici di base più completi e più diffusi per lo sviluppo e il reale potenziamento della parte superiore del corpo. I Fixed Push-Up mettono inoltre in funzione tutta la parte superiore del corpo. Disponibili anche STAND ALONE.*





## Sliding push-ups.



Sliding Push-ups brings the workout to another level, with sliding of the main handles and improve personal training. Sliding Push-ups enables the muscles to be trained in different ways.

Also available in a STAND-ALONE version.

*Lo Sliding Push-ups porta l'allenamento su un altro livello, rendendo a scorrimento le due maniglie principali e migliorando l'allenamento personale. L'attrezzo rende possibile allenare i muscoli in differenti modi.*

*Disponibile anche STAND ALONE.*

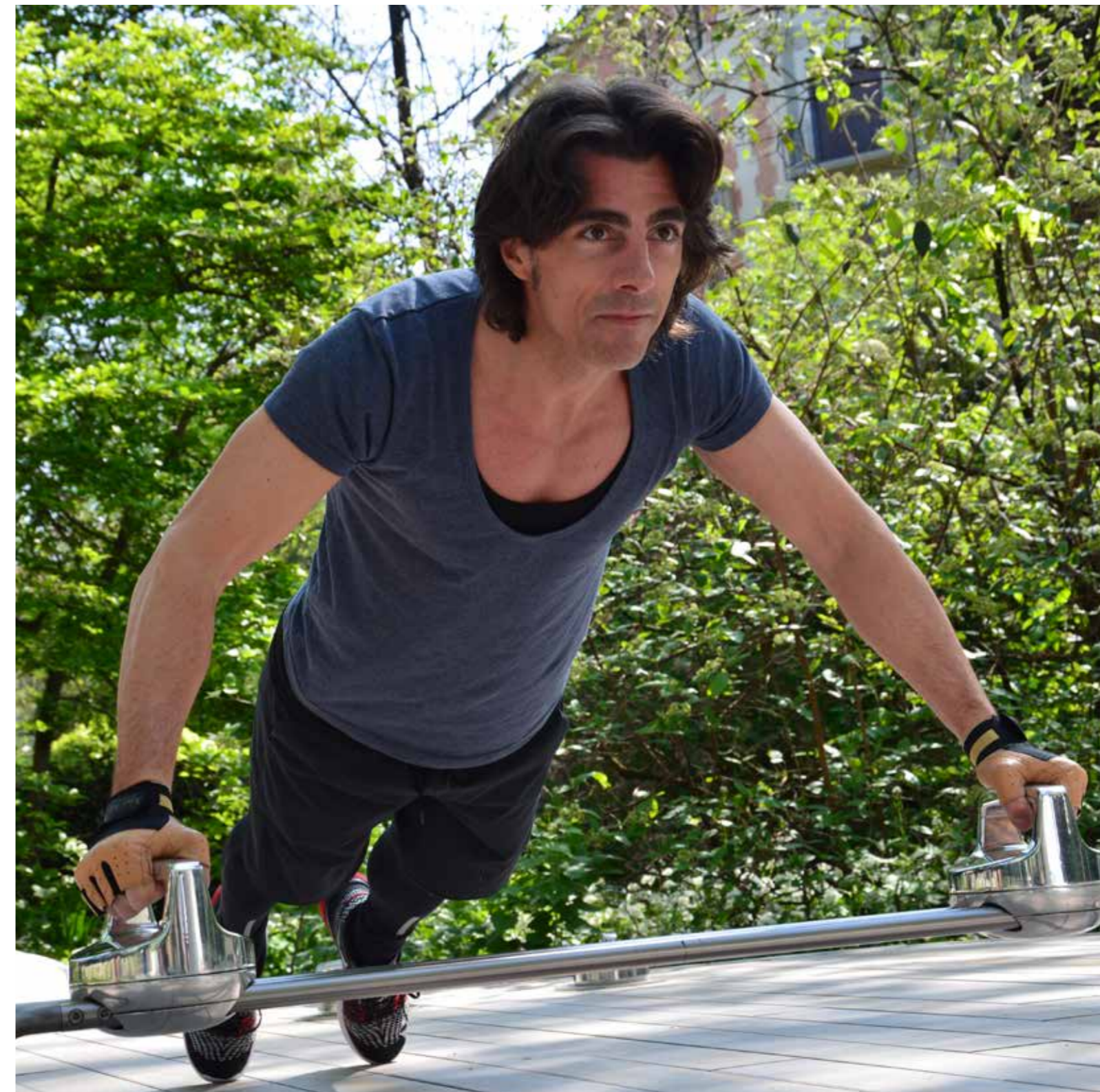





## AB Bar.

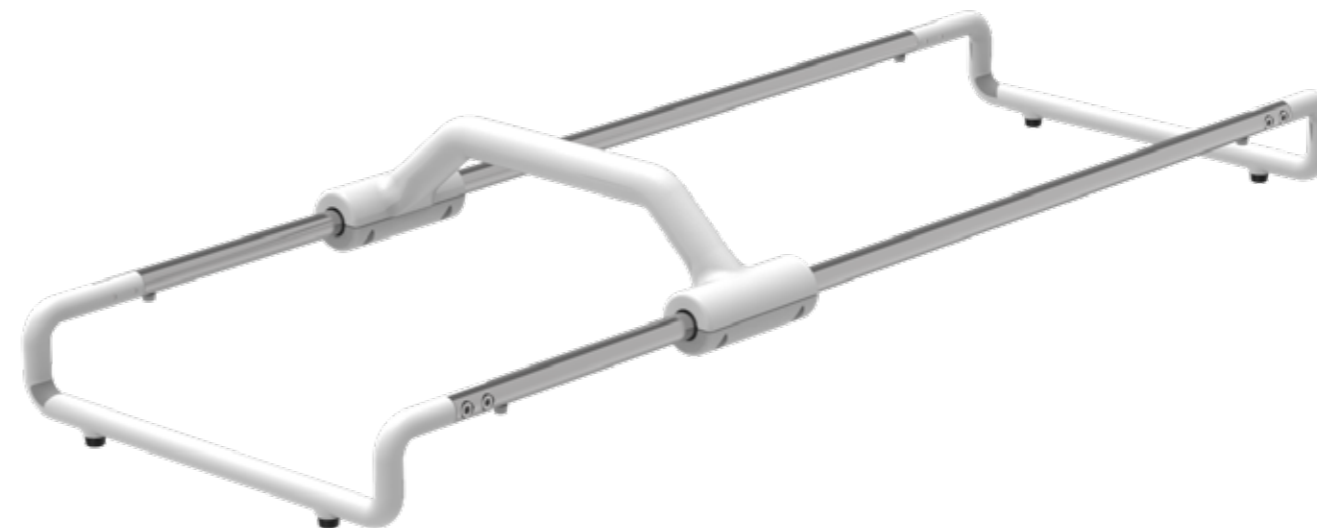

This is a professional and innovative version of an old-school ab wheel. The handlebar, incorporated into a specially designed parallel steel track, allow for a smooth, guided movement.

Also available in a STAND-ALONE version.

*Questa è una versione professionale e innovativa della tradizionale ruota per addominali. Il manubrio inserito su un carrello guida il movimento, rendendolo fluido.*

*Disponibile anche STAND ALONE.*



## Box Jump Set.

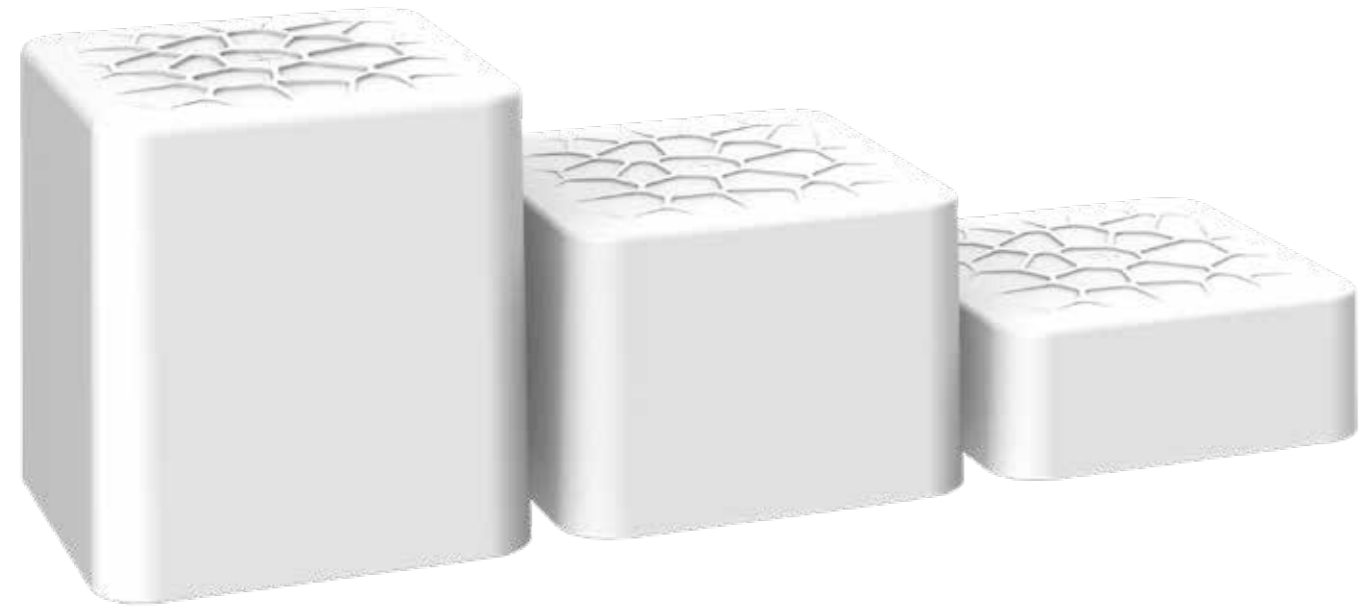

The Box Jump Set is a powerful workout tool extremely popular among fitness professionals. Box jumps allow an explosive movement, outstanding for strengthening glutes, quads and calves, while improving balance and agility. Also available in a STAND-ALONE version.

*I Box Jump rappresentano un accessorio efficace, che ha conquistato i professionisti del fitness. Consentono di compiere un movimento esplosivo, eccezionale per il potenziamento di glutei, quadricipiti e polpacci, con effetti positivi anche su equilibrio e agilità. Disponibili anche STAND ALONE.*





## Fitness Benches.



With our 3 different versions of bench: FLAT, INCLINE and DECLINE it's easy to hit the complex network of ab muscles, thanks to the combination of dumbbell and barbell exercises. Also available in a STAND-ALONE version.

*Con le nostre 3 differenti panche: FLAT, INCLINE e DECLINE è facile agire sulla complessa rete dei muscoli addominali. Questo grazie alla combinazione di esercizi con manubri e bilanceri. Disponibile anche STAND ALONE.*





## Zen Wellness Stone.

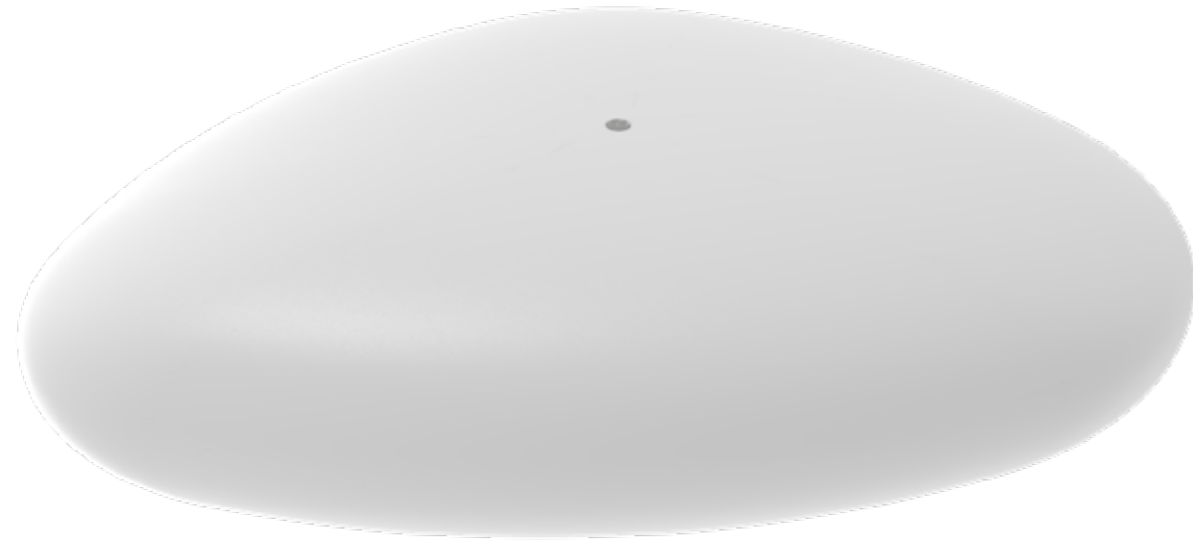

Its natural shape and size make the Zen Wellness Stone ideally suited to a wide variety of exercises ranging from Tai Chi to yoga, stretching, pilates and meditation, as well as intense work-outs.

Also available in a STAND-ALONE version.

*La forma naturale e le dimensioni rendono la Wellness Stone Zen la soluzione ideale per un'ampia varietà di esercizi che spaziano dalla pratica del Tai Chi allo yoga, allo stretching, al pilates, alla meditazione fino a intense sequenze di workout. Disponibile anche STAND ALONE.*

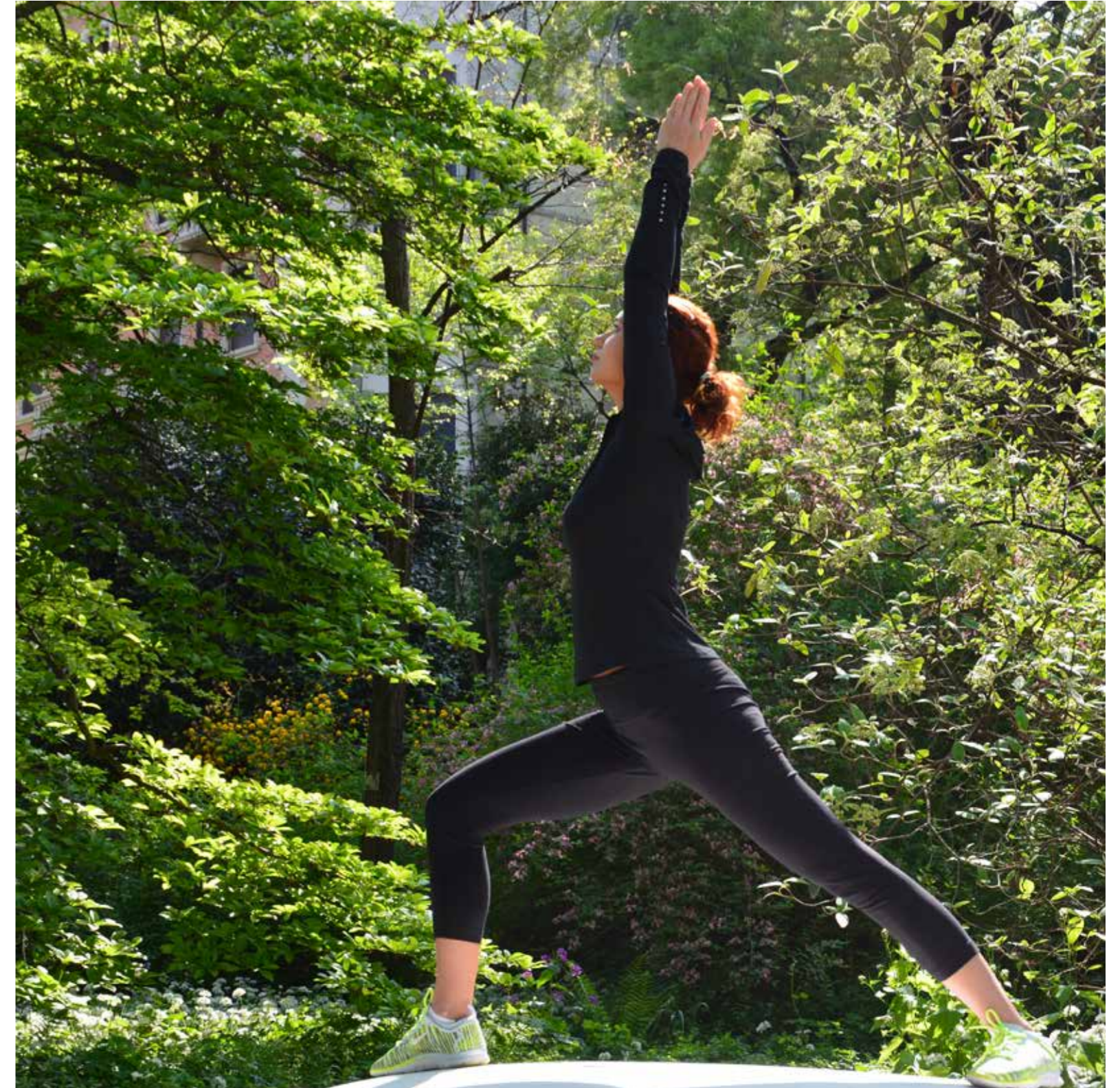



## Endurance Wellness Stone.

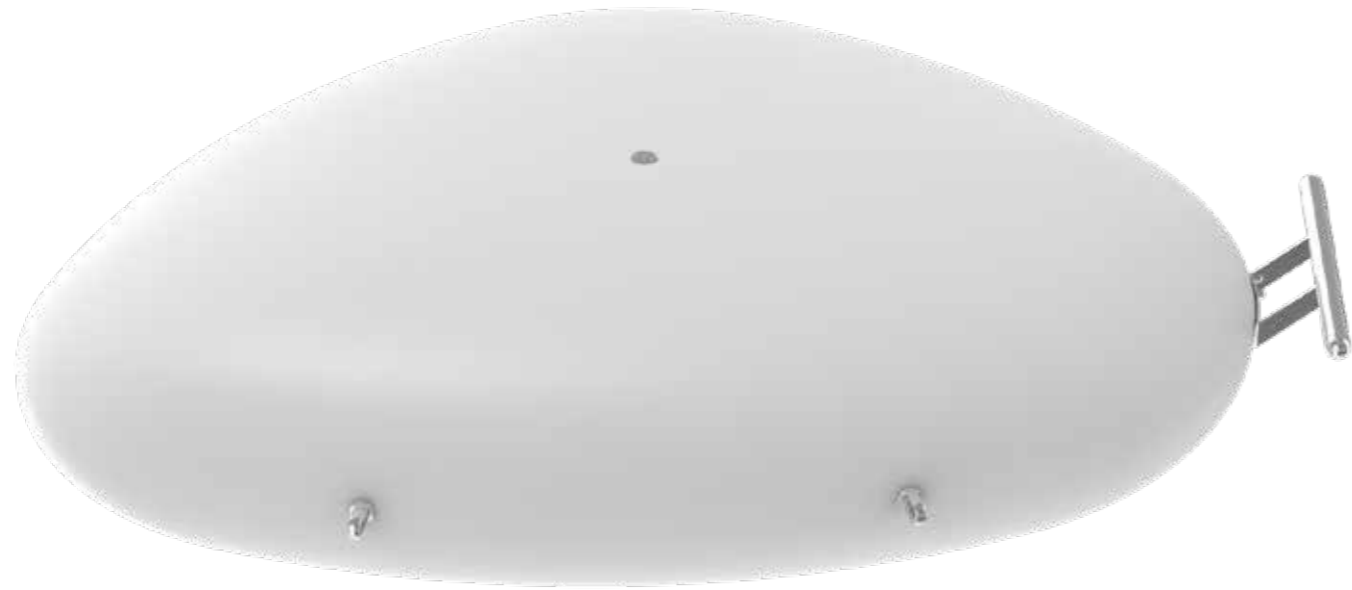

An ideal solution for a wide variety of holistic exercises, including intense sequences aimed at strengthening the chest and triceps muscles. Elastic bands with various resistance levels can be attached to the four hooks to perform strength and coordination exercises. Also available in a STAND-ALONE version.

*Una soluzione ideale per un'ampia varietà di esercizi olistici fino ad intense sequenze per il potenziamento dei muscoli del petto e dei tricipiti. I quattro hooks a cui agganciare elastici con differenti livelli di resistenza, permettono di effettuare esercizi per migliorare forza e coordinazione. Disponibile anche STAND ALONE.*







## Functional Wellness Stone.

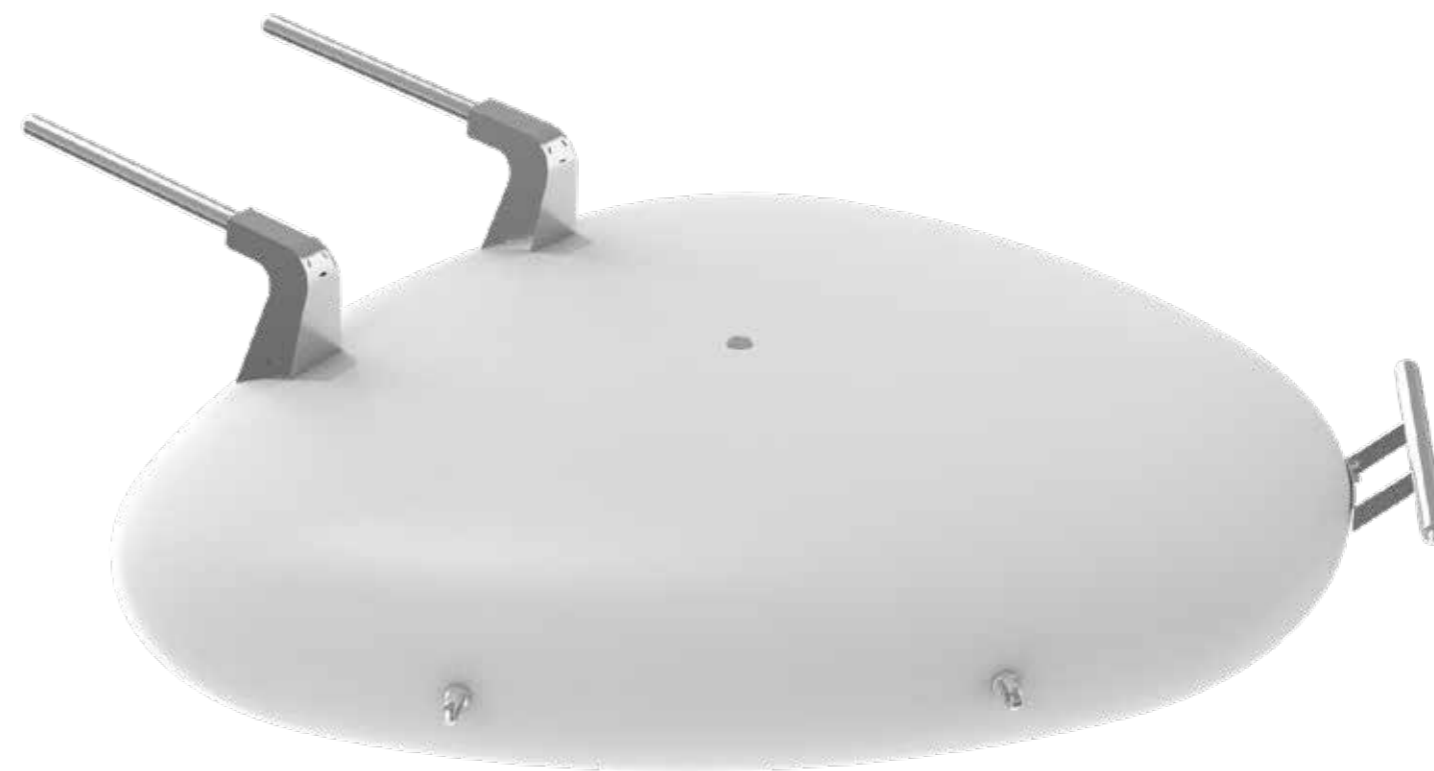

A functional sculpture measuring three square metres designed to provide a complete work-out for all the body's muscle groups. Elastic bands with various resistance levels can be attached to the four hooks to perform strength and coordination exercises.

Also available in a STAND-ALONE version.

*Una scultura funzionale di tre metri quadrati ideata per un allenamento completo di tutte le fasce muscolari del corpo. I quattro hooks a cui agganciare elastici con differenti livelli di resistenza, permettono di effettuare esercizi per migliorare forza e coordinazione.*

*Disponibile anche STAND ALONE.*





## Functional Training.

Bodyweight training is one of the best ways to build strength and make your body better at doing the things it was built to do. It's more than just using your own weight for resistance. It's a way to challenge your body, strengthen your will and arm yourself with confidence.

*L'allenamento a corpo libero è uno dei più indicati per potenziare e tonificare il corpo, offrendogli la possibilità di esprimersi al meglio. Non significa semplicemente usare il peso come resistenza, ma mettere il proprio corpo alla prova, rafforzare la propria volontà e guadagnare fiducia in se stessi.*





This is H-FARM's place

Playing sports benefits your body and your brain. Love and respect your body and remember it's where your soul resides.

BMX, Skate and Roller area

"ask the fall feels to fly"  
L. Mirra

ATTENTION  
USE ONLY

YOU ARE ALLOWED TO USE YOUR OWN VEHICLES INSIDE THE AREA, BUT IT IS NECESSARY TO WEAR THE SAFETY EQUIPMENT.

READ CAREFULLY BEFORE ENTERING

USERS MUST NOT USE THE TRACK ALONE.  
Check the park and inform a user when in surveillance of an user.

PROHIBITED USES:  
- No alcohol  
- No drugs  
- No smoking

IT IS FORBIDDEN TO USE THE TRACK FOR OTHER PURPOSES THAN THE ONE INTENDED.

and fun.

Outdoor Training

"Physical fitness is not only one of the most important keys to a healthy body, it is the basis of dynamic and creative intellectual activity"

John F. Kennedy







## MyBeast.

Engineered for professional athletes and sports teams, MyBeast is the essence of intense, highly-focused and result-charged training.

Conceived to help you advance and sculpt your body, build strength, power, agility, stamina and character, the MyBeast Innovative Workout System brings together the best of sports science, functional training and performance-driven design.

*Realizzata per soddisfare le esigenze di singoli atleti e di intere squadre di professionisti dello sport, MyBeast è l'essenza della preparazione fisica intensa e che non conosce limiti.*

*Ideata per aiutarvi a raggiungere i vostri obiettivi, incrementando potenza, forza, agilità, resistenza e determinazione, MyBeast riesce a combinare il meglio delle scienze sportive, del training funzionale e del design ad alta performance grazie al suo sistema di allenamento innovativo.*



## Stage: Monkey Bars.

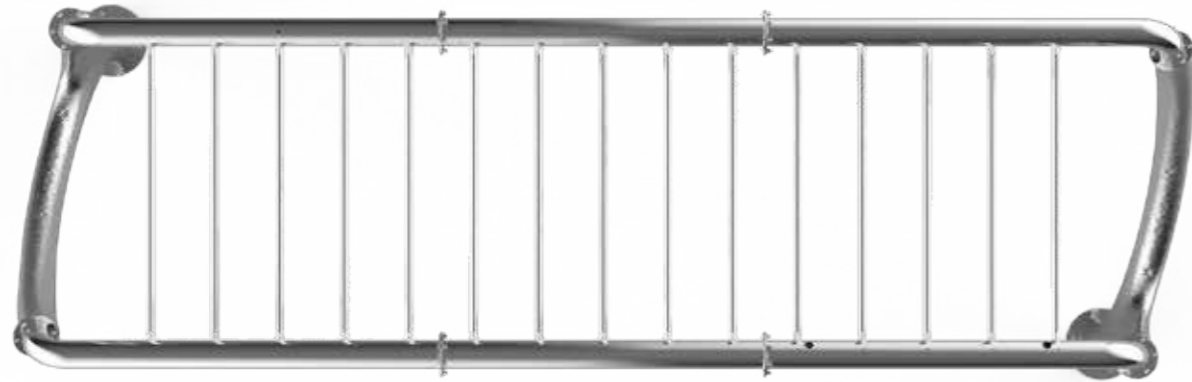

Thanks to MyBeast's prominent design, this monkey bar could be the biggest and longest you've ever seen. Workout options are diverse and fun: from pull-ups to swinging from one bar to another.

*Grazie al prominente design di MyBeast, questa monkey bar potrebbe essere la più grande e la più lunga che abbiate mai visto. Le opzioni di workout sono diverse e divertenti: dai pull-up al dondolare passando tra una barra e l'altra.*

## Stage: Power Rack.



Power Rack is a weight training station for barbell exercises. The cage is also useful for performing limited-range exercises: these include rack pulls and rack lockouts, a bench press variation limited to just the upper portion of the lift. Stall Bars provide further options and creativity for stretching, improving body posture and toning muscles.

*Power Rack rappresenta un attrezzo per l'allenamento con il bilanciere. La gabbia è utile per eseguire anche altri esercizi: rack pulls e rack lockouts e una variazione della bench press limitata solo alla parte superiore. Stall Bars offre ulteriori opzioni e creatività per lo stretching, migliorare la postura del corpo e tonificare i muscoli.*



## Stage: multi pull-ups.

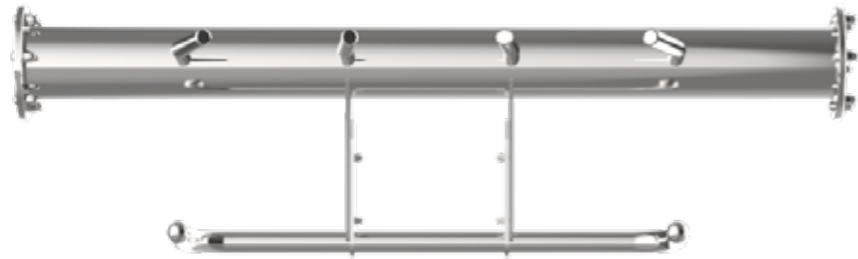

The four pull up handles and pull-up bar of this stage feature a unique design to help you develop strength, endurance and balance by working out the same muscles from all angles.

*Le quattro maniglie e la barra per pull-up di questo stage sono caratterizzate da un design unico che permette di accrescere forza, resistenza ed equilibrio facendo lavorare uno stesso muscolo da qualsiasi angolazione.*

## Stage: stall bars + dip.

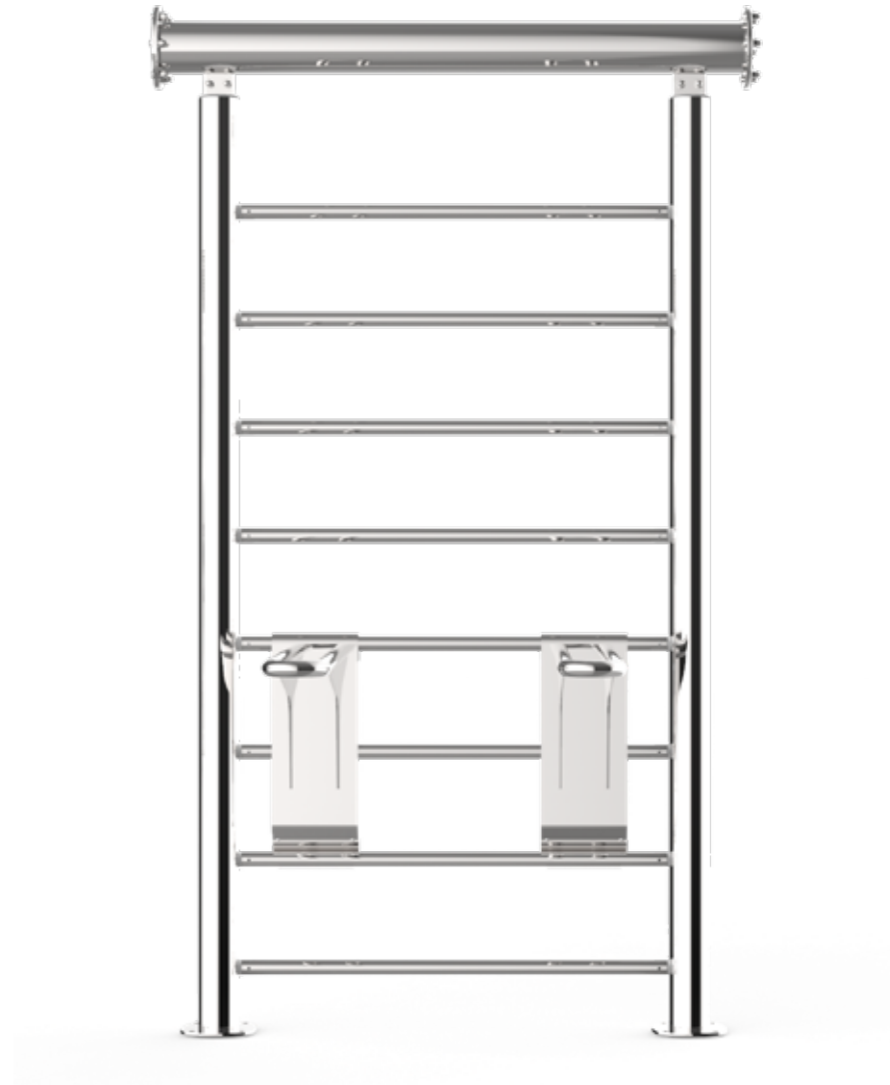

*This stage is unbeatable in terms of versatility, functionality and creativity. It can be used for an impressive number of stretching, flexibility and body posture exercises as well as muscle toning.*

*Questo stage non teme paragoni in termini di versatilità, funzionalità e creatività. Può essere utilizzato per eseguire tantissimi esercizi di stretching, flessibilità e postura come pure per tonificare la muscolatura.*



## Stage: sliding push-ups.

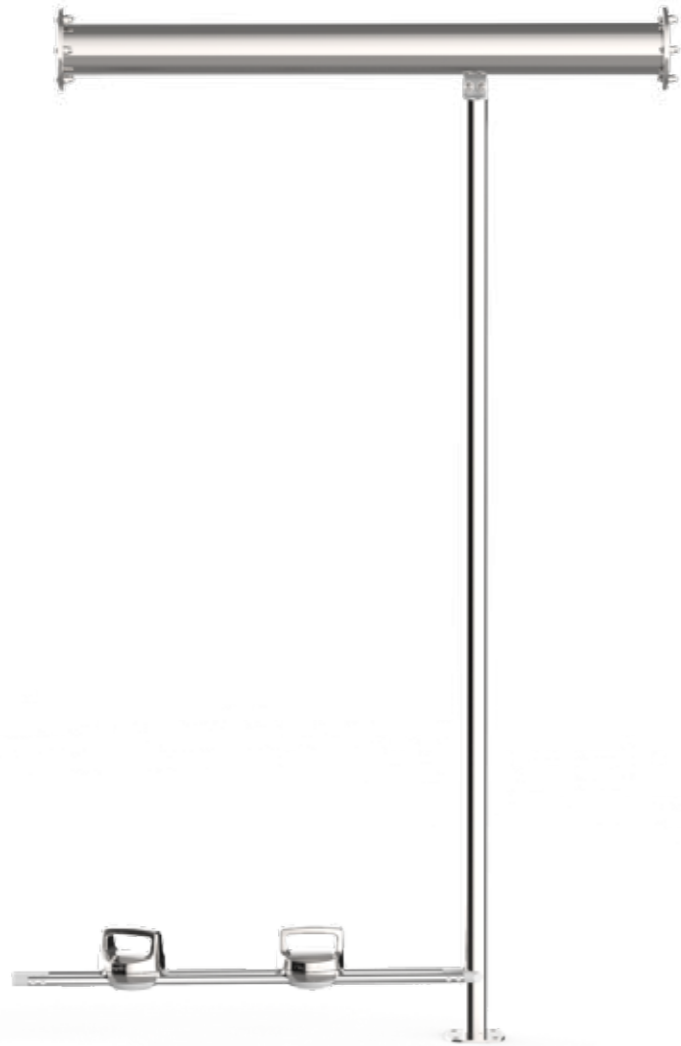

This stage is a continuation of the upper body and core strength series. Sliding push ups allow you to effectively build triceps and chest muscles both by performing regular exercises or boosting difficulty level with a sliding motion.

*Questo stage prosegue nel potenziamento del busto. Gli sliding push up consentono di potenziare efficacemente tricipiti e pettorali sia eseguendo l'esercizio in modo tradizionale sia incrementandone la difficoltà con l'inserimento di uno scivolamento.*

## Stage: punching bag.



This stage is an area dedicated to boxing, kickboxing and martial arts. A fast-paced, high-intensity heavy bag training is a strategic addition to more traditional exercises.

*Questo stage è dedicato alla boxe, al kickboxing e alle arti marziali. Un allenamento veloce e molto intenso con il sacco è un plus strategico agli esercizi più tradizionali.*



## Stage: rings.



This stage, dedicated to rings training, is one of the most diverse, challenging and fun ways to strengthen your upper body known to man.

*Questo stage è dedicato all'allenamento con gli anelli, uno dei modi più particolari, impegnativi e divertenti per potenziare la parte superiore del corpo.*

## Stage: flying pull-ups.

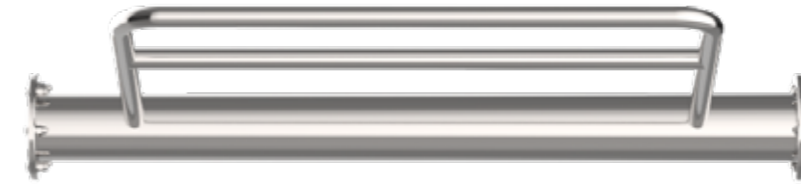

This stage has been engineered to help you develop exceptional strength, resistance and balance through incremental exercise routines.

*Questo stage è stato ideato per aiutarvi a sviluppare forza, resistenza ed equilibrio grazie a routine sempre più impegnative.*

## Stage: sliding pull-ups.



This stage has been designed to help you efficiently exercise the muscles of the back, arms and abdominals.

*Questo stage è stato progettato per allenare in modo efficace i muscoli dorsali, le braccia e gli addominali.*

## Stage: multi tool.



This stage is the most multi-functional station of MyBeast. Ropes, barbells and resistance bands are excellent in helping you create greater awareness of your body, and significantly improve endurance, intensity, performance, strength and proprioception.

*Questo stage è la stazione più multifunzione di MyBeast. Funi, bilancieri ed elastici sono ideali per lavorare sulla consapevolezza del corpo e potenziarne in modo significativo resistenza, intensità, prestazioni, forza e propriocezione.*



## Stage: hanging handles.

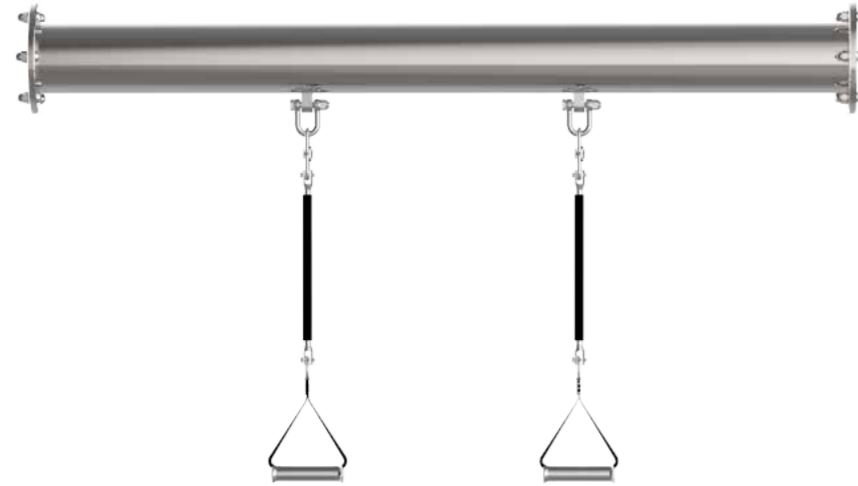

This stage is a strategic station that combines the fitness benefits of the rings, but offers greater grip stability with the 2 sturdy, anti-slip handles.

As most of the exercises here are done with the body suspended above the ground, greater muscle effort and balance is required to fight the force of gravity.

*Questo stage è una stazione strategica che abbina i benefici degli anelli a una maggiore stabilità di presa grazie alle due robuste maniglie antiscivolo.*

*Poiché gran parte degli esercizi viene eseguita in sospensione, sono necessari un maggior sforzo e più equilibrio per contrastare la forza di gravità.*

## Stage: butterfly handle.



The elegant and sturdy steel Butterfly of this stage allows a tight grip and maximally recruits the latissimus dorsi muscle. It also challenges your core, arm and back muscles in a new way.

*L'elegante e robusta farfalla di acciaio di questo stage consente la presa stretta. Butterfly Handle mette alla prova i muscoli del busto, braccia e dorso come mai prima d'ora.*

## Stage: pole ladder.

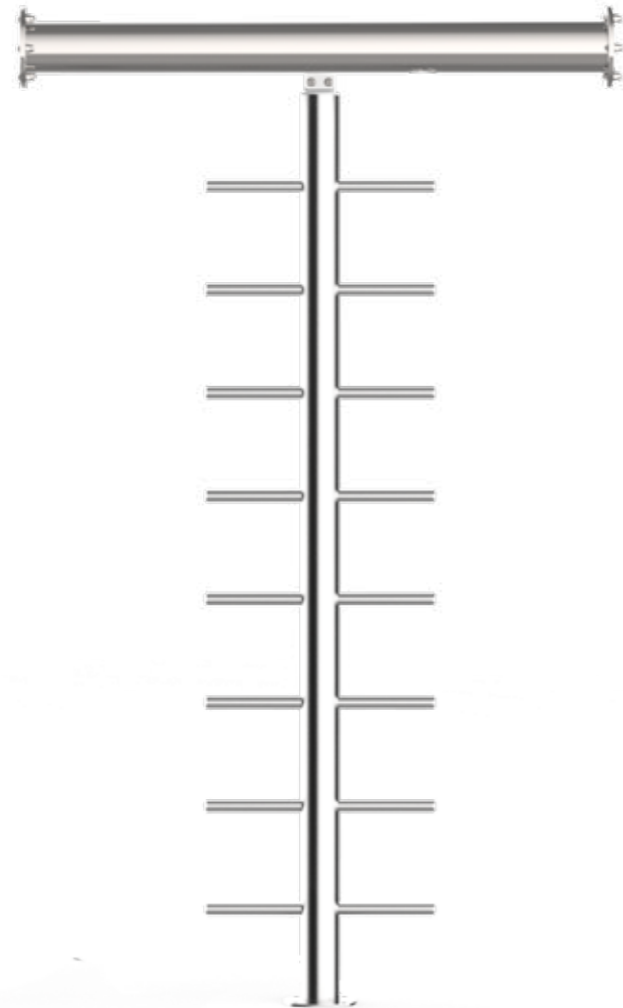

At the name implies, this stage is a reference point for those who want to sharpen their fitness skills and prepare the body for the more challenging exercises. This is a great station for fitness beginners.

*Come dice il nome, questo stage è il punto di riferimento per chi vuole affinare le proprie capacità e preparare il corpo per esercizi più impegnativi. È una stazione fantastica per i neofiti del fitness.*

## Stage: pull-up handles.



This stage completes the workout routine, challenging your upper core muscles a little further using the 2 specific handles.

*Completate la vostra routine con questo stage ritornando a eseguire una serie di pull-up e facendo lavorare in maniera più profonda i muscoli del busto grazie alle due maniglie.*



# MyBeast Sport Performance.

- Monkey Bars
- Multi Pull-Ups
- Stall Bars & Dips
- Sliding Push-Ups
- Punching Bag
- Rings
- Flying Pull-Ups
- Sliding Pull-Ups
- Multi Tool
- Hanging Handles
- Butterfly Handle
- Pole Ladder
- Pull Up Handles

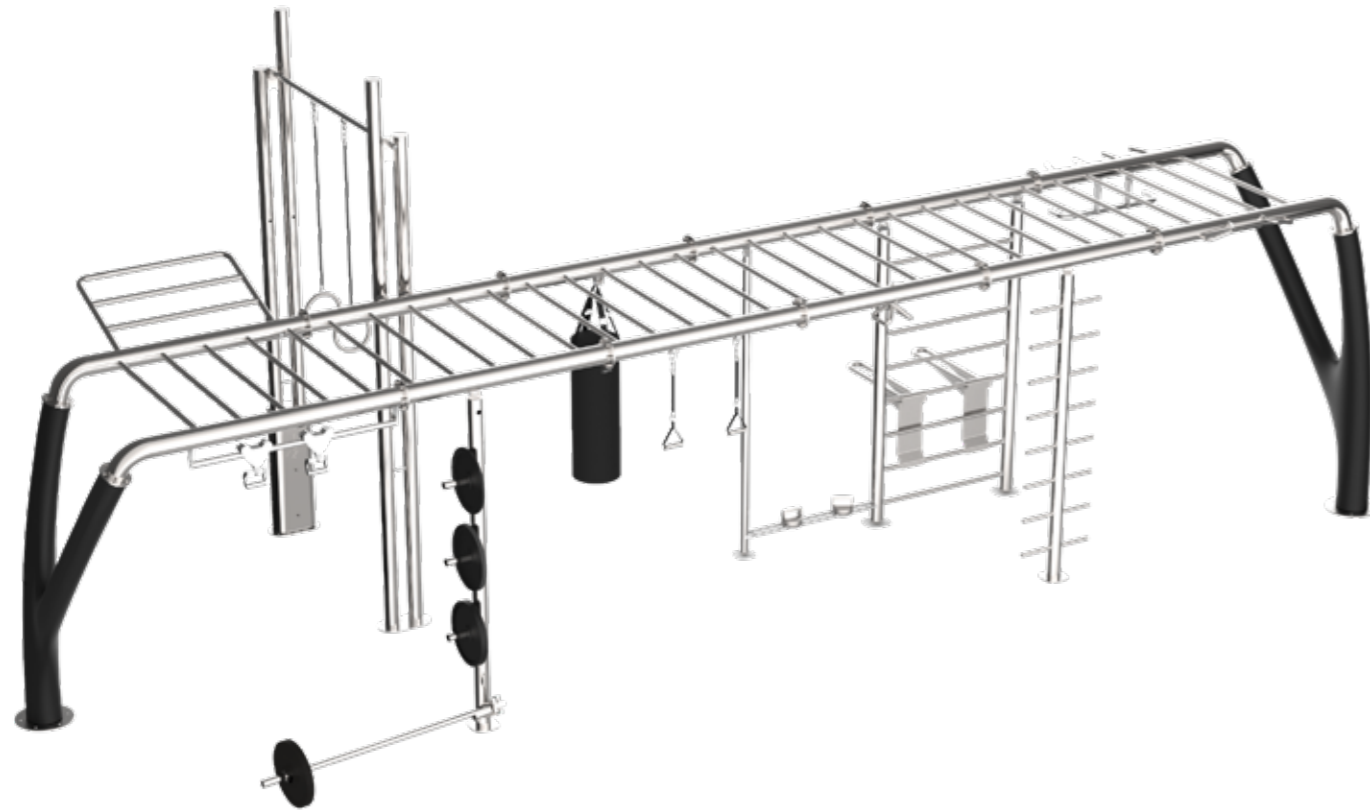

Featuring over 12 workout stations, MyBeast Luxury is versatile, effective and adaptable to different sports disciplines. MyBeast is also the first “seamless” fitness product, making it possible to sculpt the body and work on all the major muscle groups.

*Con oltre 12 postazioni, il MyBeast Luxury si presenta versatile, efficace e adattabile a differenti discipline sportive. MyBeast è inoltre il primo prodotto fitness senza soluzione di continuità, che offre la possibilità di scolpire il nostro corpo e lavorare su tutti i principali gruppi muscolari.*





# MyBeast Beach Club.

- Monkey Bars
- Multi Pull-Ups
- Stall Bars & Dips
- Flying Pull-Ups
- Sliding Pull-Ups
- Multi Tool
- Punching bag

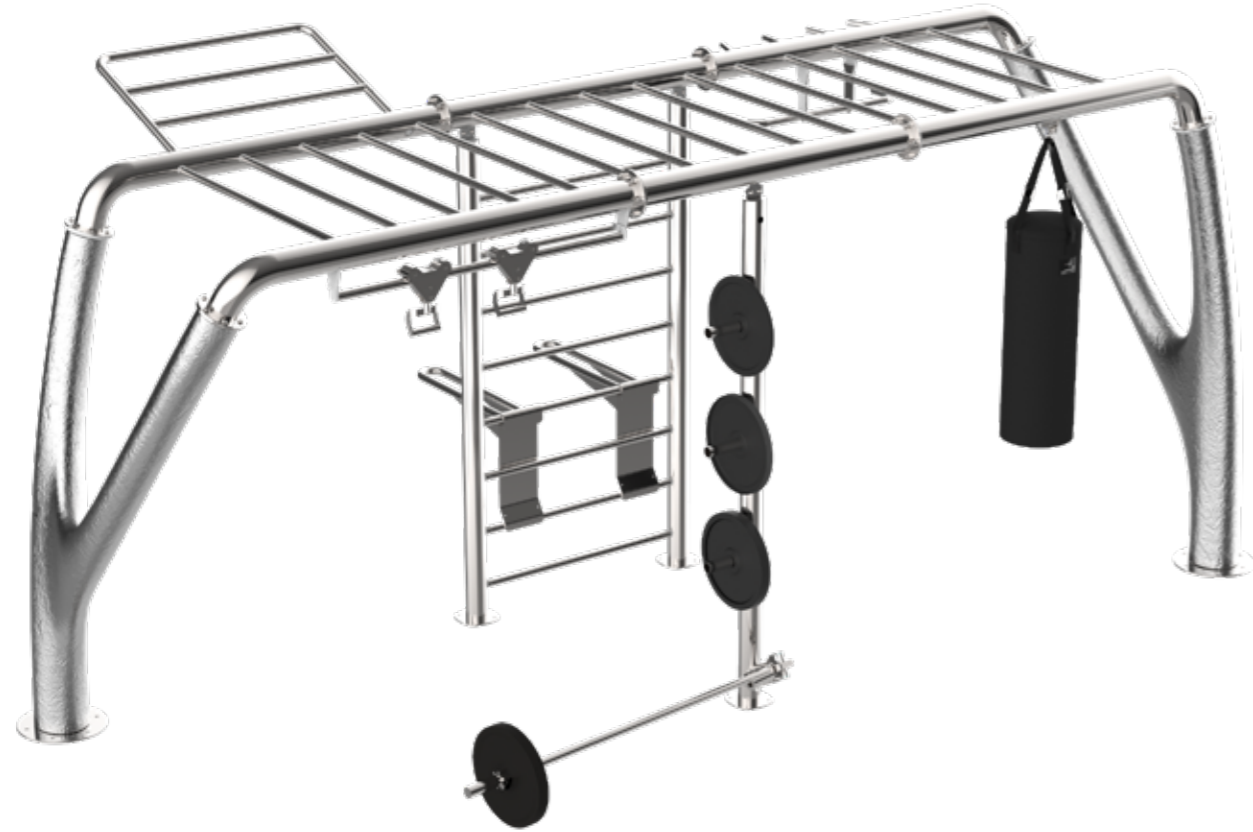

MyBeast Beach Club optimizes the training space, providing a real "alpha-breed workout machine" in less than 7 meters. The configuration can be customized according to specific training requirements.

*Il MyBeast Beach Club ottimizza lo spazio di esercizio, offrendo una vera e propria "macchina per l'allenamento Alpha-breed", in meno di 7 metri. La configurazione può essere personalizzata in base alle proprie necessità.*





# MyBeast Edge.

- Monkey Bars
- Multi Pull-Ups
- Stall Bars & Dips
- Flying Pull-Ups
- Sliding Pull-Ups
- Multi Tool
- Punching bag

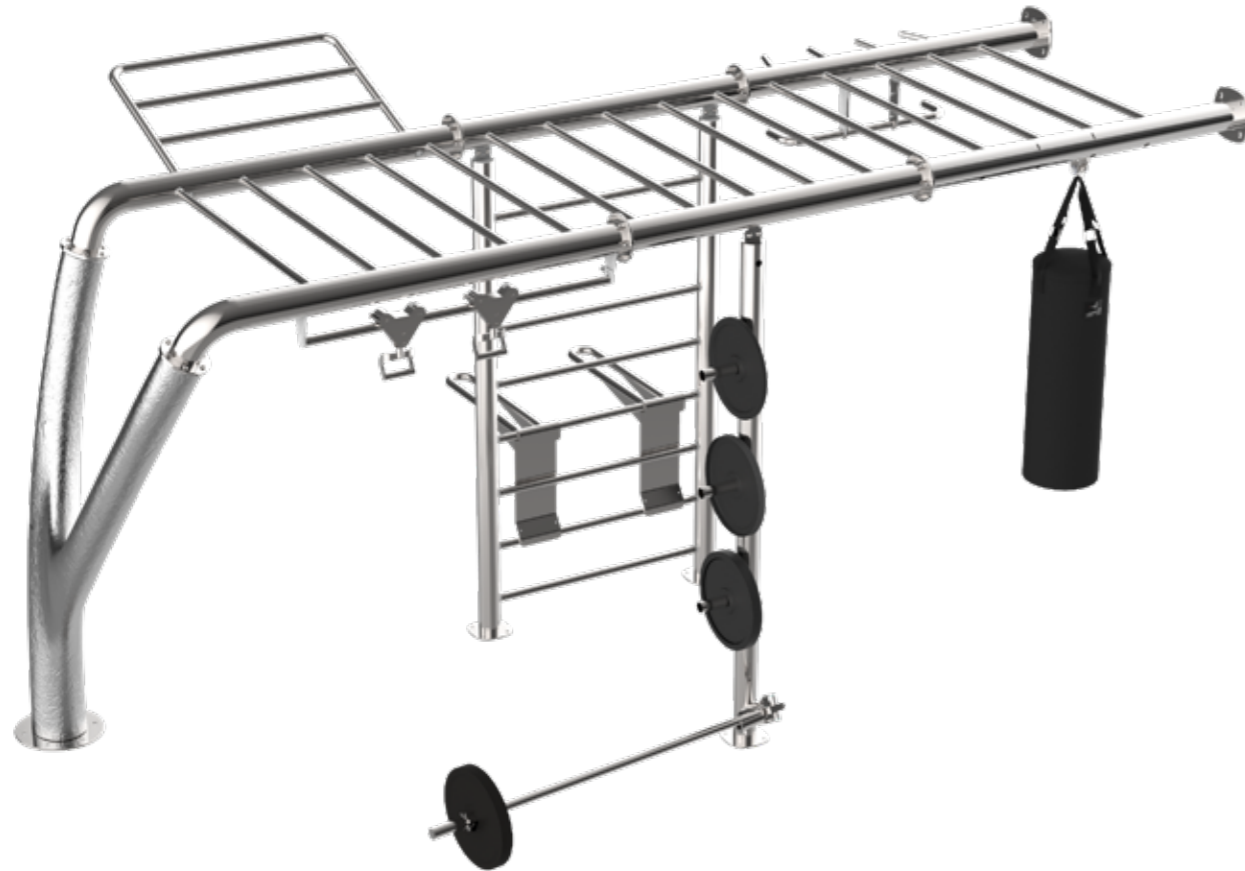

MyBeast Edge is more compact than MyBeast Sport Performance and MyBeast Beach Club. Functional and with a single "branch", it has been devised for easy installation on an existing support structure and can be customized according to specific training requirements.

*MyBeast Edge rappresenta una soluzione compatta rispetto al MyBeast Sport Performance e al Beach Club. Con solamente un "ramo", rappresenta un elemento funzionale che può essere facilmente installato su strutture portanti già esistenti. La configurazione può essere personalizzata in base alle proprie necessità.*





# MyBeast Beach Club Power Rack.

- Monkey Bars
- Multi Pull-Ups
- Stall Bars & Dips
- Flying Pull-Ups
- Sliding Pull-Ups
- Power Rack
- Punching bag

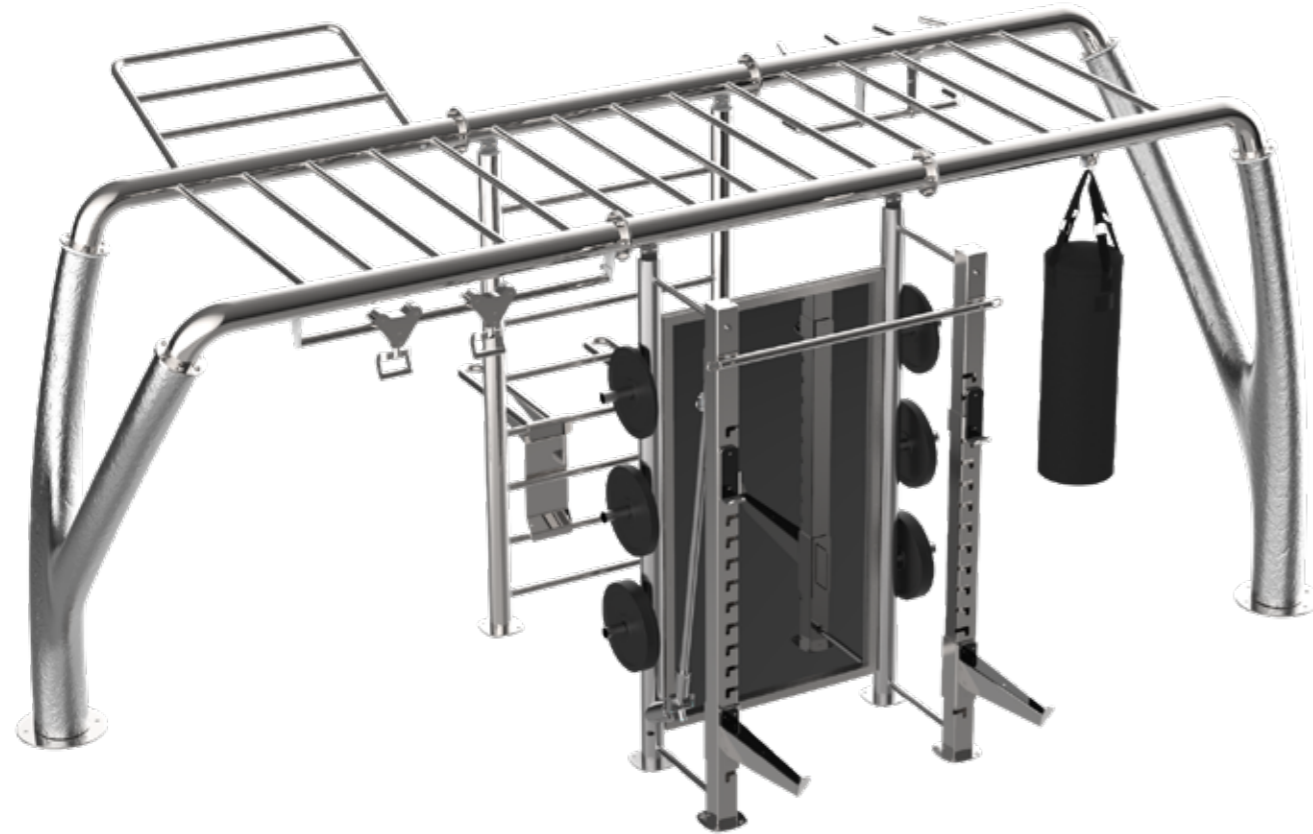

MyBeast Beach Club optimizes the training space, providing a real “alpha-breed workout machine” in less than 7 meters. The configuration is customized with a special Power Rack station with mirror, pull-ups bar + suspended hooks and landmine.

*Il MyBeast Beach Club ottimizza lo spazio di esercizio, offrendo una vera e propria “macchina per l’allenamento Alpha-breed”, in meno di 7 metri. Questa configurazione include uno speciale Power Rack con specchio, barra pull-ups + ganci per l’allenamento in sospensione e un landmine.*

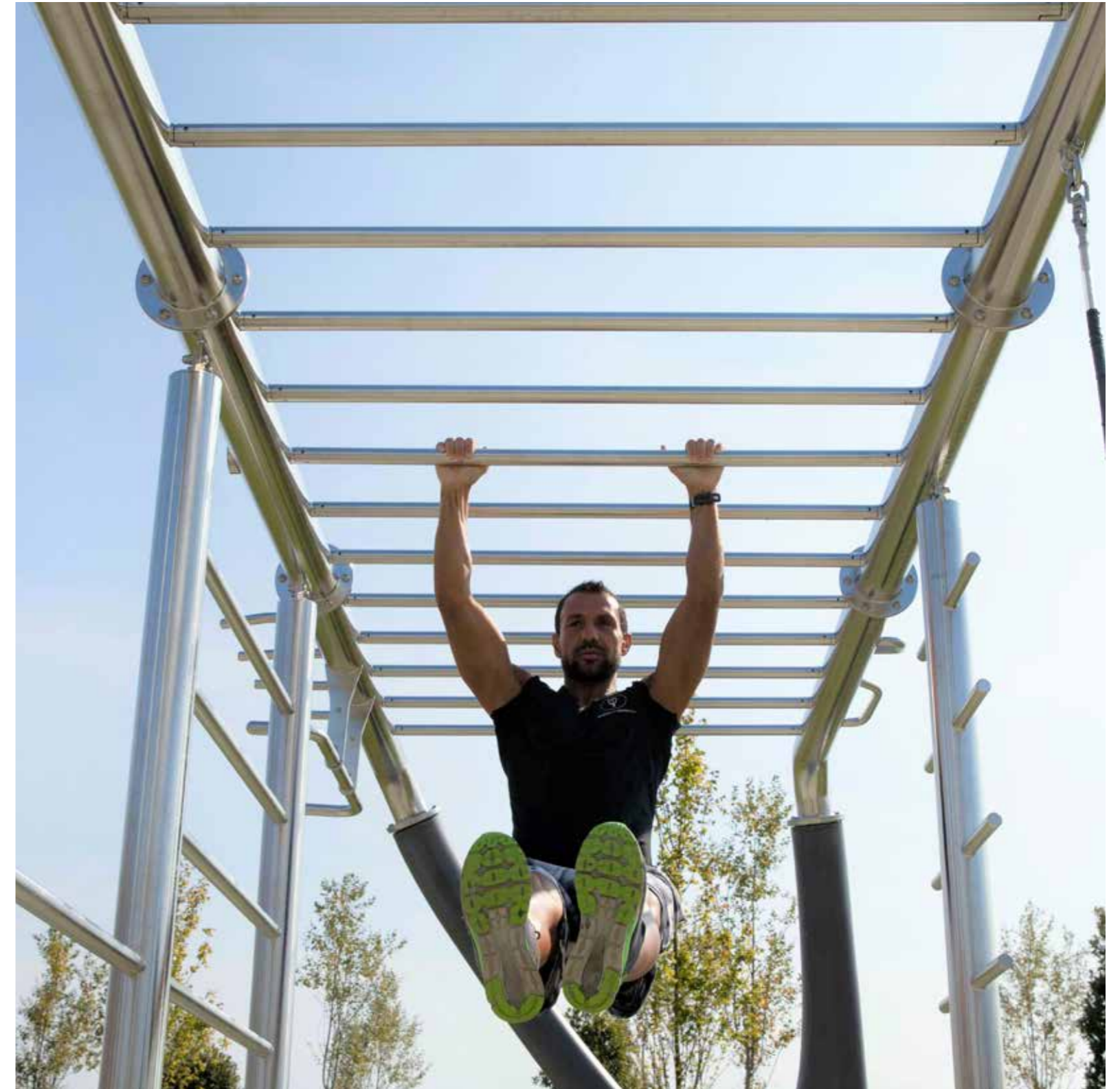



# MyBeast All Power Rack.

Power Rack x4

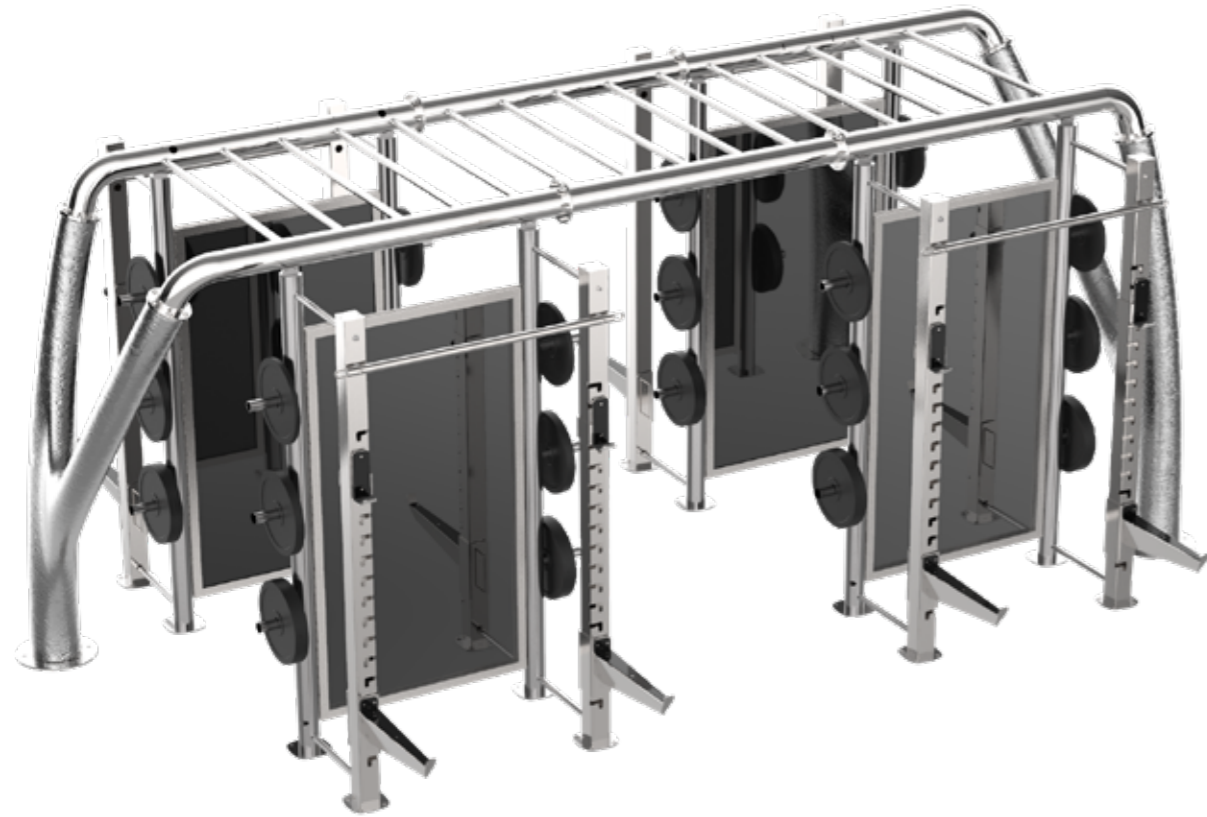

MyBeast All Power Rack is the ultimate expression of bodyweight training. 4 complete stages with mirror, Power Rack, weights holder, pull-up bar and suspended hooks offer maximum functionality and compactness in just 6 meters.

*MyBeast All Power Rack è la massima espressione dell'allenamento con i pesi. 4 postazioni complete di specchio, Power Rack, porta pesi, barra di trazione e ganci per l'allenamento in sospensione, offrono il massimo della funzionalità e compattezza in soli 6 metri.*







## Sculpture & Fitness.

Sports and art are amongst the oldest activities that we, as humans, have practiced. For thousands of years, men have strived to become stronger and faster—pushing their limits and sculpting their bodies. Artists then would try to capture the perfection of the human body and immortalize it in their works of art.

Even the modern Olympic Games initially included artistic competitions, with Gold Medals being awarded to the best sculptors, painters, writers, and architects.

*Sport e arte sono tra le attività più antiche che noi, come esseri umani, abbiamo praticato. Per migliaia di anni, gli uomini hanno cercato di diventare più forti e più veloci, spingendo i loro limiti e scolpendo i loro corpi. Gli artisti quindi hanno cercato di catturare la perfezione del corpo umano e immortalarlo nelle loro opere d'arte.*

*Anche le Olimpiadi moderne, inizialmente, includevano gare artistiche, con medaglie d'oro assegnate ai migliori scultori, pittori, scrittori e architetti.*





## Mylsle.

Mylsle combines elegance, exclusivity and versatility in an outdoor gym measuring as little as 16 to 24 sq m. It also sets new standards for personal training and group fitness classes, allowing up to 6 people to work out at the same time. Never before has outdoor wellness equipment been elevated to the level of functional sculpture. This contemporary and functional outdoor gym is the perfect solution for holiday apartment complexes, exclusive resorts and hotels, private gardens and luxury yachts.

*Mylsle unisce eleganza, esclusività e versatilità in una palestra outdoor da 16 a 24 mq. Mylsle segna nuovi standard per personal trainer e gruppi di allenamento, permettendo l'allenamento fino a 6 persone contemporaneamente.*

*Mai prima d'ora un sistema di esercizi per l'outdoor è stato elevato a scultura funzionale. Questa palestra outdoor, contemporanea e funzionale, rappresenta la soluzione perfetta per le residenze, hotel e resort esclusivi, giardini o parchi privati e imbarcazioni di lusso.*







# Mylsle David.

- Stability board
- Battle rope loop
- Parallettes
- Pistols
- High box jump
- Flat bench
- Rotary push-ups
- Ground hooks

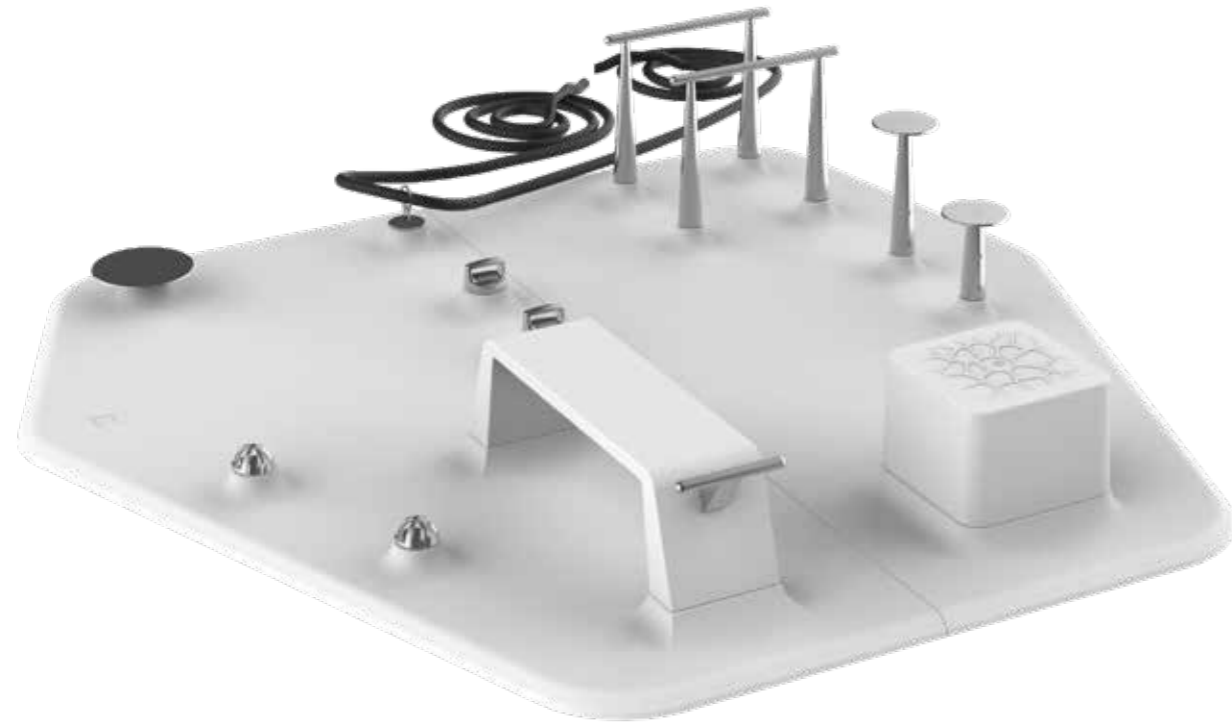

Perfect where space is limited, Mylsle is a revolutionary outdoor solution that anticipates 4 out of 5 top fitness trends, giving users exclusive access to 500+ exercises.

*Perfetto per spazi più ristretti, Mylsle è una piattaforma rivoluzionaria per l'outdoor che anticipa 4 su 5 delle migliori tendenze del Fitness, offrendo agli utenti un accesso esclusivo a più di 500 esercizi.*





# Mylsle Goliath.

- Suspension training hooks
- Stability board
- Battle rope loop
- Parallettes
- Pull-ups station
- High box jump
- Flat bench
- Rotary push-ups
- Ground hooks
- Pistols

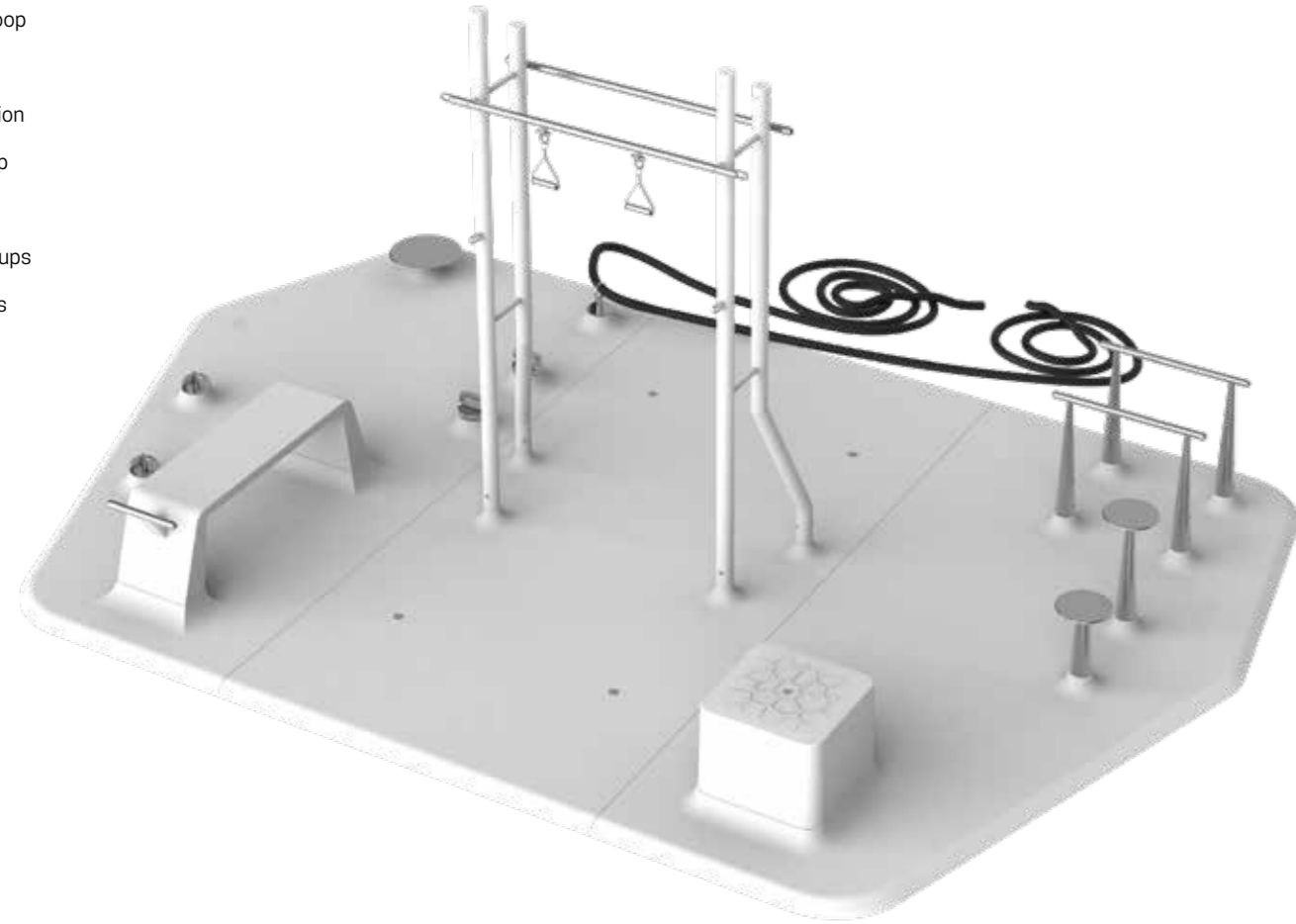

Mylsle Goliath represents the evolution of the "David" model, larger and with a Pull Up station. The platform can also include additional accessories, such as the AB Bar and Sliding Push-Ups.

*Mylsle Goliath rappresenta l'evoluzione del modello "David", con dimensioni maggiori e la Pull Up Station. La piattaforma inoltre può includere all'interno ulteriori accessori come l'AB Bar e lo Sliding Push-Ups.*





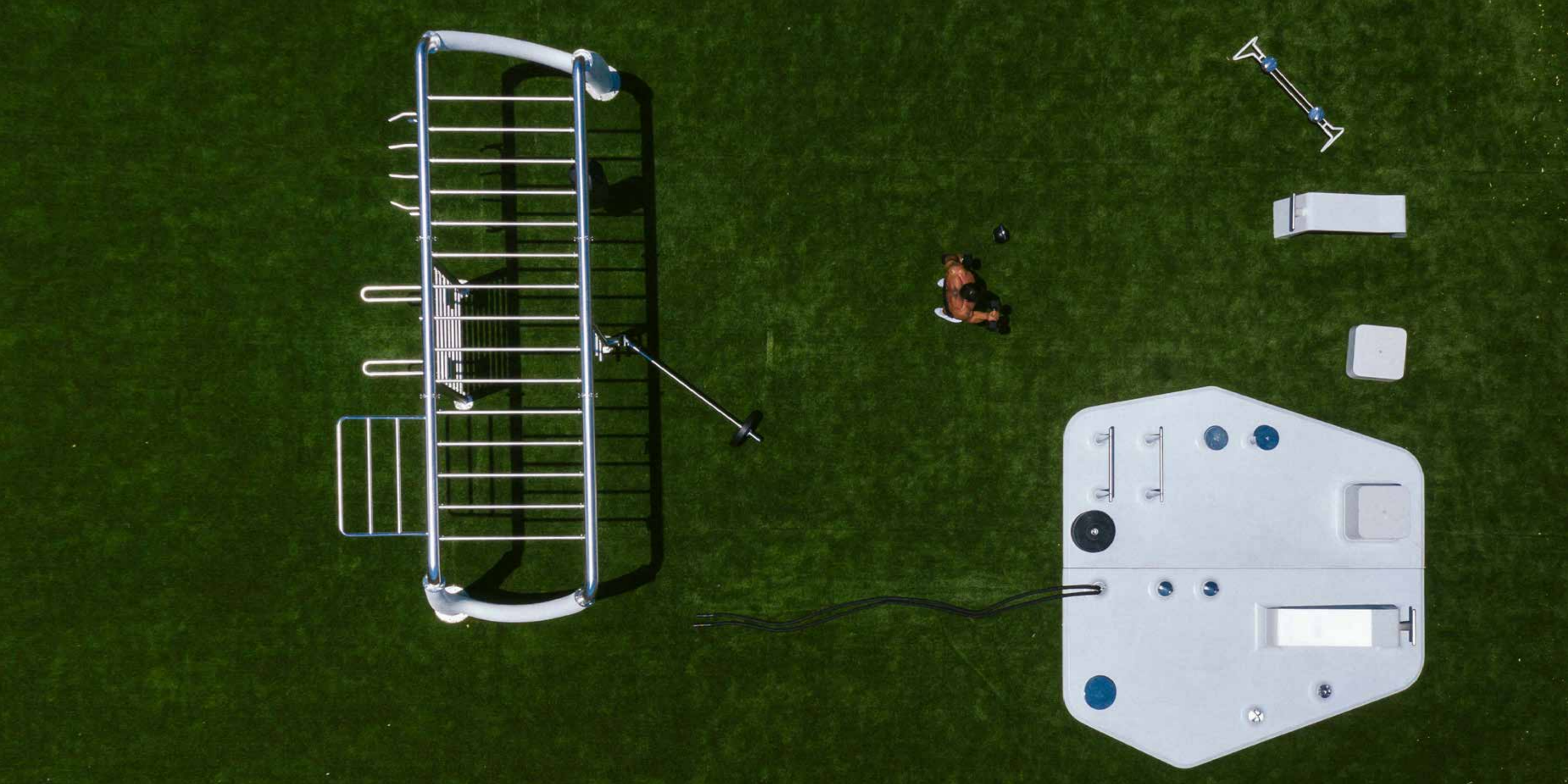



# Mylsle Rocco.

- Suspension training hooks
- Stability board
- Battle rope loop
- Parallettes
- Pull-ups station
- High box jump
- Flat bench
- Rotary push-ups
- Ground hooks
- Pistols

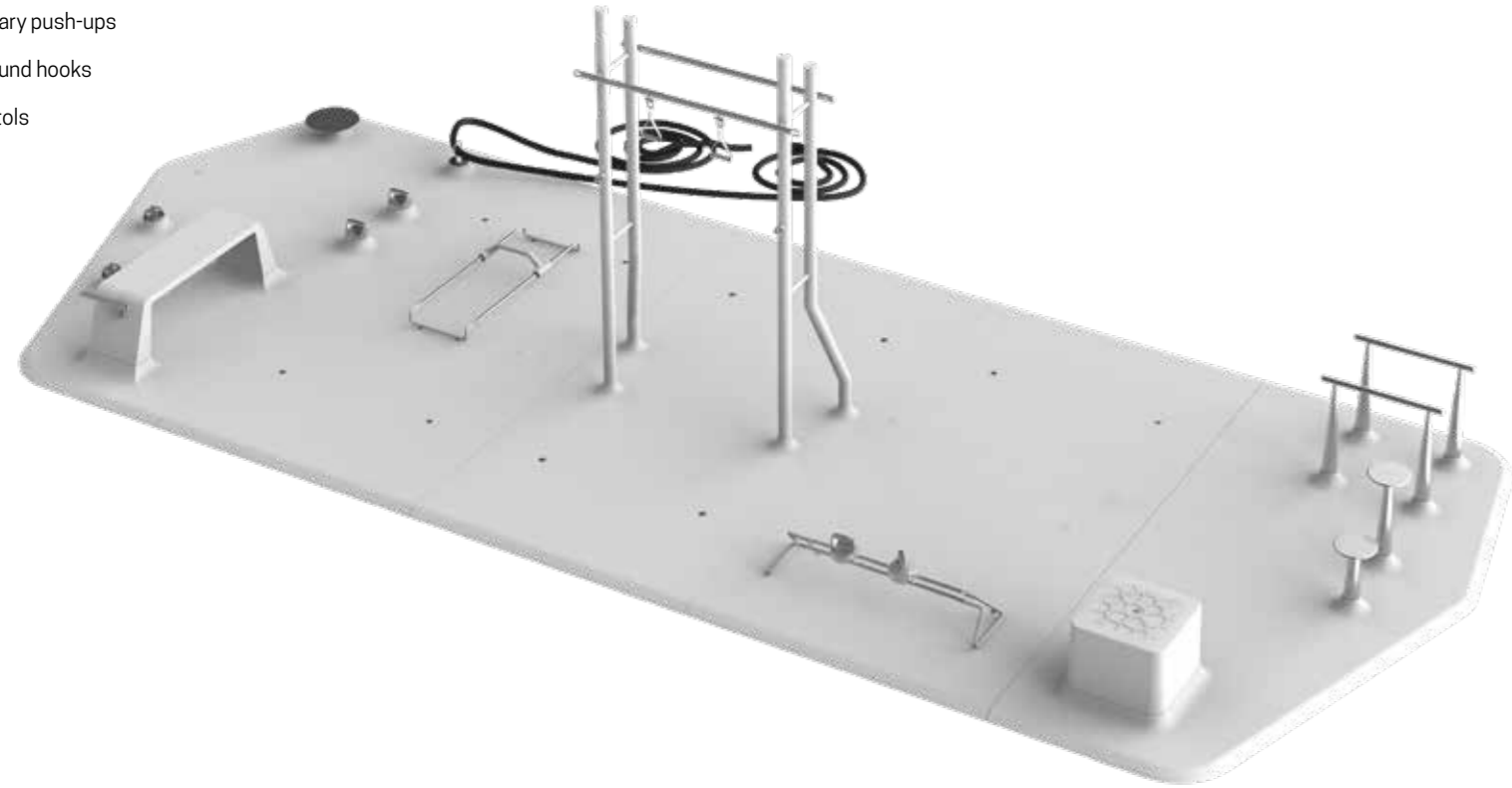

The evolution of Mylsle Goliath: the largest Mylsle solution.

*L'evoluzione del Mylsle Goliath: la soluzione Mylsle più grande.*









## MyCali Pro.

Calisthenics is a method of strength training which uses the body's own natural weight to provide a full body workout. The MyCali Pro structures allow a variety of muscle groups to be targeted, to train and follow a series of progressions.

*Calisthenics è un metodo di allenamento che utilizza il peso naturale del corpo per fornire un allenamento completo per il corpo. Con le strutture MyCali Pro, è possibile indirizzare l'esercizio su una varietà di gruppi muscolari, allenandosi e seguendo diverse progressioni.*







## Double AB Bar.

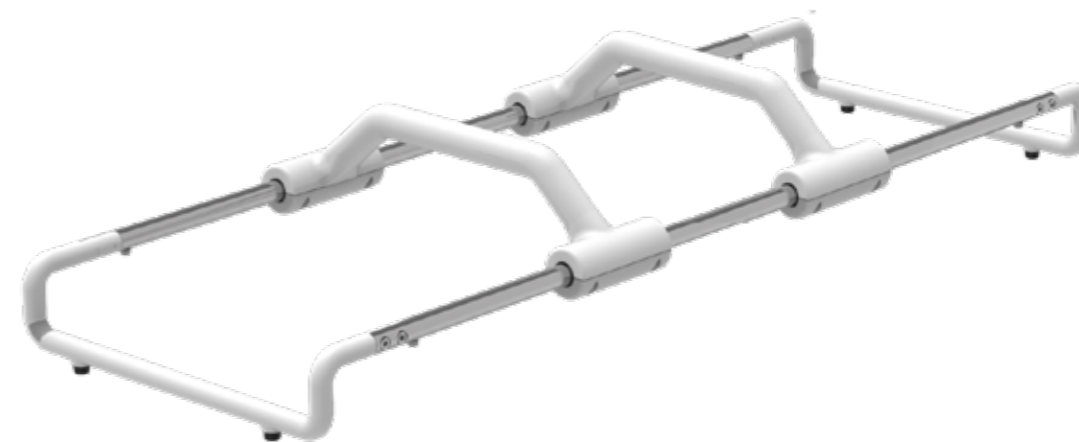

This is a professional and innovative version of an old-school AB Bar. The two handlebars, incorporated into a specially designed parallel steel track, allow for a smooth, guided movement, giving the opportunity to do different exercises. Also available in a STAND-ALONE version.

*Questa è una versione professionale e innovativa della tradizionale ruota per addominali. I due manubri inseriti su un carrello guidano il movimento, rendendolo fluido e permettono di svolgere diversi esercizi. Disponibile anche STAND ALONE.*



## Converging Bars.



Functional equipment to develop balance and strength in triceps, shoulder muscles and chest.

Although designed for the most demanding users, a wide range of workout exercises are possible.

*Accessorio funzionale per lo sviluppo dell'equilibrio e della forza nei tricipiti, muscoli della schiena e petto.*

*Sebbene sia stato progettato per gli utenti più esigenti, è possibile eseguire una vasta gamma di esercizi di allenamento.*

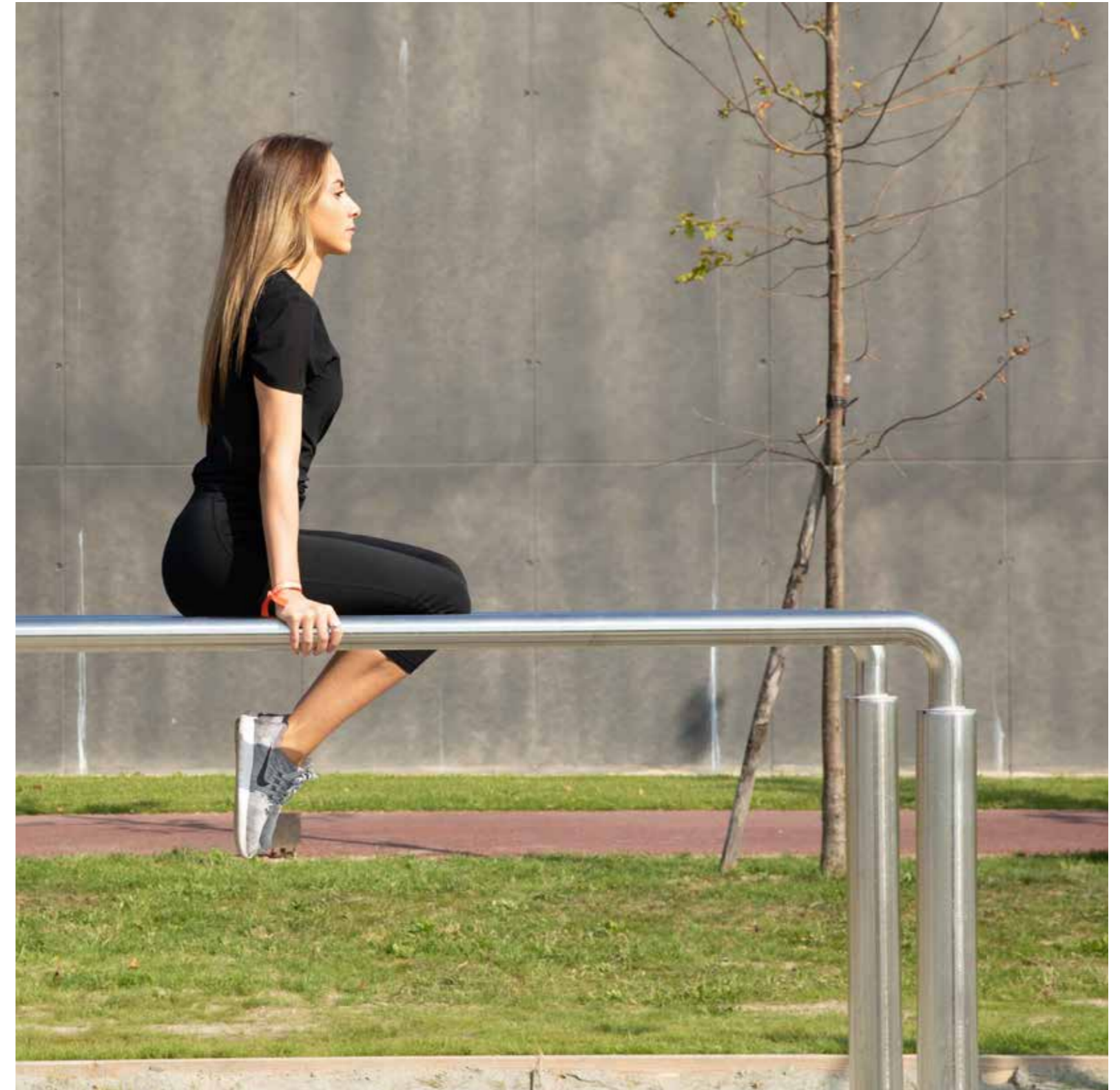



## Triple Bars.



Functional equipment with three bars, to develop balance and strength in triceps, shoulder muscles and chest. Although designed for the most demanding users, a wide range of workout exercises are possible.

*Accessorio funzionale a tre barre, per lo sviluppo dell'equilibrio e della forza nei tricipiti, muscoli della schiena e petto. Sebbene sia stato progettato per gli utenti più esigenti, è possibile eseguire una vasta gamma di esercizi di allenamento.*





## Flag Pole.



Inspired by acrobatic and dancing disciplines, the flag pole workout improves balance and flexibility, reinforcing upper body strength, particularly arms and abs.

*Ispirato da acrobati e discipline di danza, l'allenamento con il flag pole migliora l'equilibrio e la flessibilità, rafforzando la forza sulla parte superiore del corpo, in particolare le braccia e gli addominali.*





## Bi-level Pull-ups.



Designed to increase mass and strength in the upper body. Two-level pull-up bars provide complete and multifunctional exercises for beginners and professional users.

*Progettato per aumentare la massa e la forza nella parte superiore del corpo.*

*Le barre di sollevamento a 3 livelli consentono esercizi completi e multifunzionali per principianti e professionisti.*





## Tri-level Pull-ups.

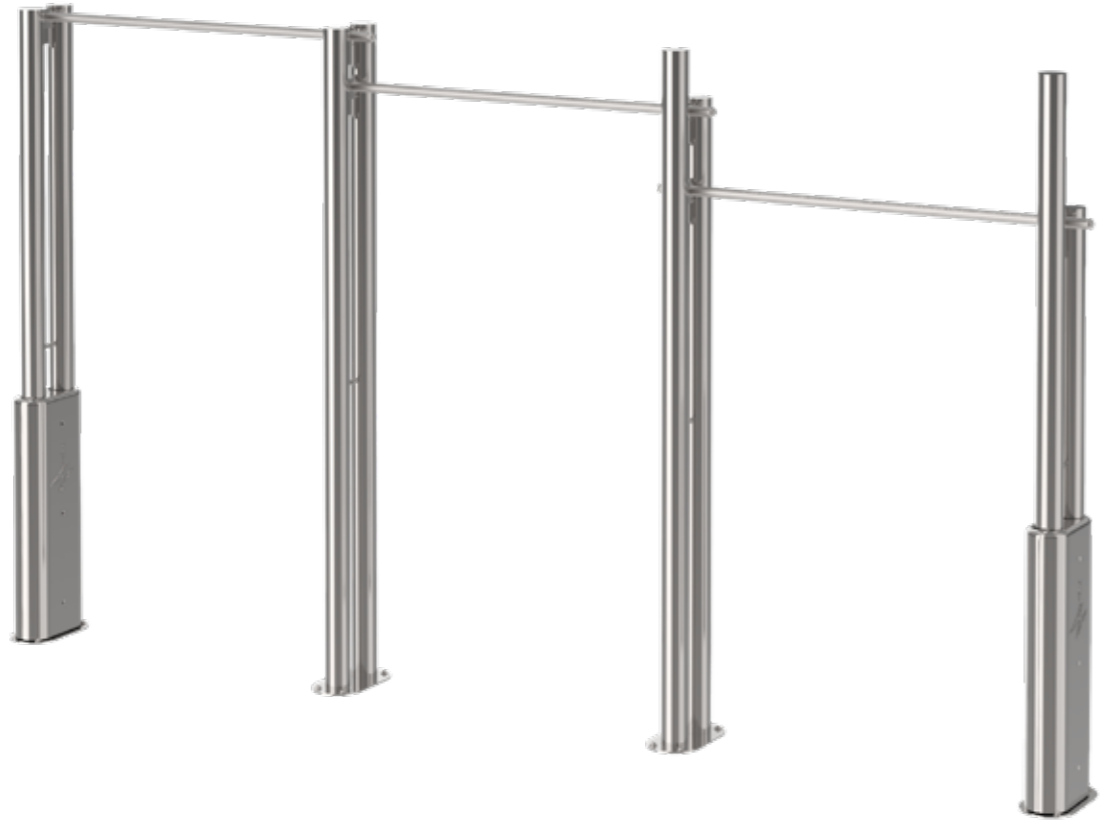

An advanced take on the classic Pull-ups bar, this equipment provides variety to upper body and core strength and endurance training. Although designed for the most demanding users, even beginners can perform basic functional exercises.

*Una versione avanzata della classica barra Pull-up, questa attrezzatura offre una varietà di allenamento per la parte superiore del corpo, la forza e la resistenza. Sebbene sia progettato per gli utenti più esigenti, anche i principianti possono eseguire esercizi funzionali di base.*











## Technology.

The MyEquilibria App has been designed to guarantee its users full support and guidance, facilitated by an impressive library of video exercises for each installation and accessory, direct access to MyEquilibria personal trainers and exclusive workout sequences created by some of the world's top celebrity wellness experts. We've created the most polished interface and packed it with intuitive social features to help you connect with like-minded people, access the profiles of MyEquilibria certified trainers, challenge friends and have fun socializing.

*L'app MyEquilibria è stata ideata per garantire agli utenti un supporto a tutto tondo, grazie alla vastissima library di video di tutti gli esercizi eseguibili con ogni singolo attrezzo e accessorio, al contatto diretto con i personal trainer e alle sequenze di esercizi studiati ad hoc da esperti di wellness di fama mondiale.*

*Abbiamo creato un'interfaccia essenziale e l'abbiamo poi integrata con funzioni social estremamente intuitive, che consentono di entrare in contatto con altri appassionati di fitness, accedere ai profili dei personal trainer certificati MyEquilibria, divertirsi socializzando.*



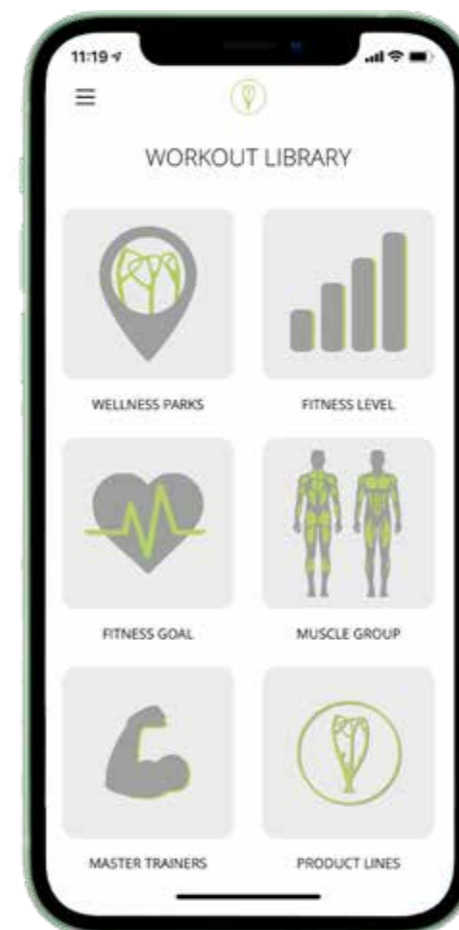

## MyEquilibria App.

A single app to access over 500 video tutorials, discover parks and installations, learn about products and meet other users.

*Una singola app per accedere a più di 500 video tutorials, scoprire i parchi e le installazioni, conoscere i prodotti e incontrare altri utenti.*

Available for iOS and Android:  
*Disponibile per iOS e Android:*

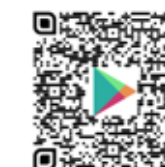





Explore the most famous MyEquilibria Wellness Parks, reach your location easily and start training by accessing the video tutorials of each product in an easy and intuitive way.

*Scopri i parchi MyEquilibria più famosi, raggiungi la location facilmente e inizia ad allenarti grazie ai video tutorial per ogni prodotto, in modo facile e intuitivo.*

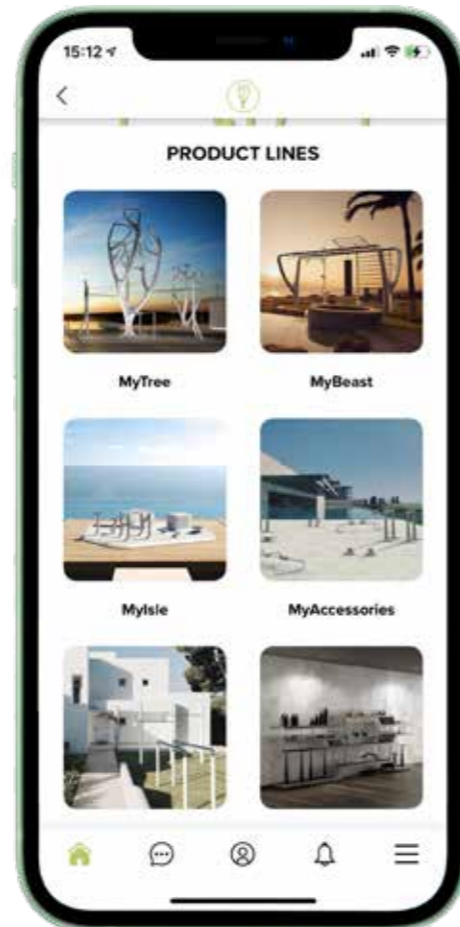

Discover the MyEquilibria indoor and outdoor collections, their characteristics and the exercises you can perform.

*Scopri le collezioni Indoor e Outdoor MyEquilibria, i prodotti e gli esercizi possibili.*

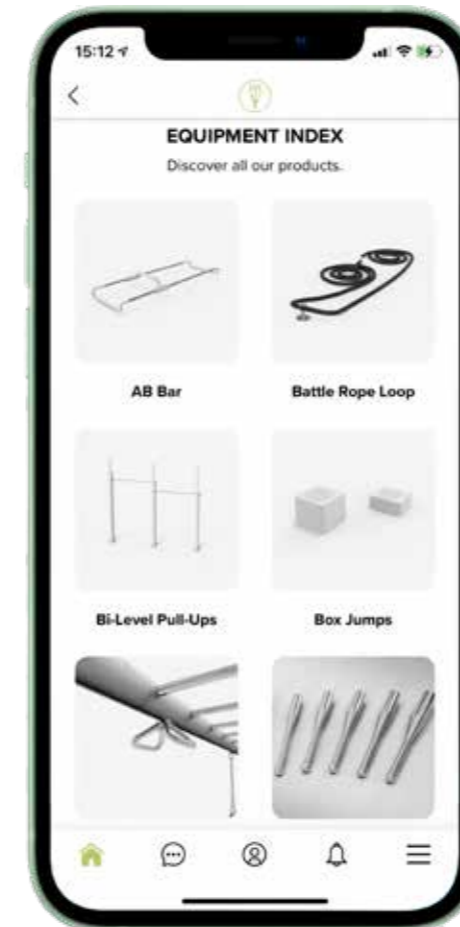

Explore the entire MyEquilibria world by browsing the catalog of products in the Wellness Park in alphabetical order.

*Scopri il mondo MyEquilibria scorrendo il catalogo prodotti in ordine alfabetico.*

## Explore.

The best coaches and athletes from around the world have collaborated in the development of a library of practical, functional and effective video exercises.

*I migliori allenatori e atleti provenienti da tutto il mondo hanno collaborato allo sviluppo di una libreria di video esercizi pratica, funzionale ed efficace.*



## Customize your workout.

Thanks to the new intuitive style of the app, it's easy to create a personalized workout and train the right muscles, choosing your level of difficulty, your favorite equipment and the wellness goals you want to achieve.

*Grazie alla nuovo style intuitivo dell'app, è facile creare un allenamento personalizzato ed allenare i muscoli corretti, scegliendo il livello di difficoltà, l'accessorio e l'obiettivo da raggiungere.*

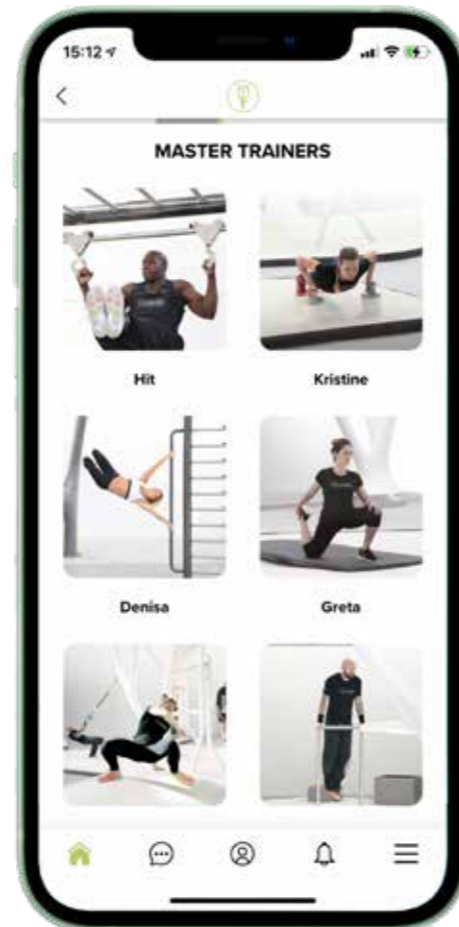

If a particular trainer reflects your skills or trains in a way you like, you can follow all of their videos directly in this dedicated section.

*Se un particolare trainer rispecchia le tue abilità o si allena in un modo che ti piace, puoi seguire tutti i suoi video comodamente in questa sezione dedicata.*

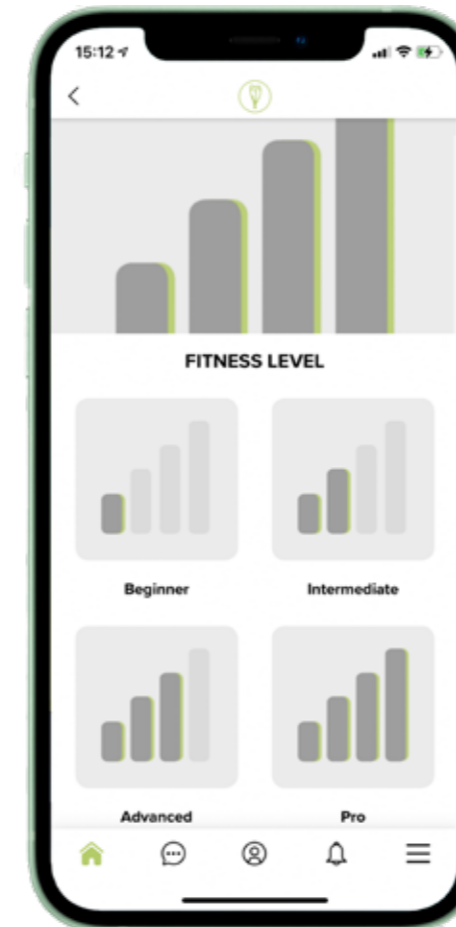

Find the exercises that best suit your needs and abilities. Choose between 4 different difficulty levels, from beginner to professional athlete.

*Trova gli esercizi che meglio rispondono alle tue necessità e abilità. Scegli tra 4 differenti livelli di difficoltà, da principiante ad atleta.*

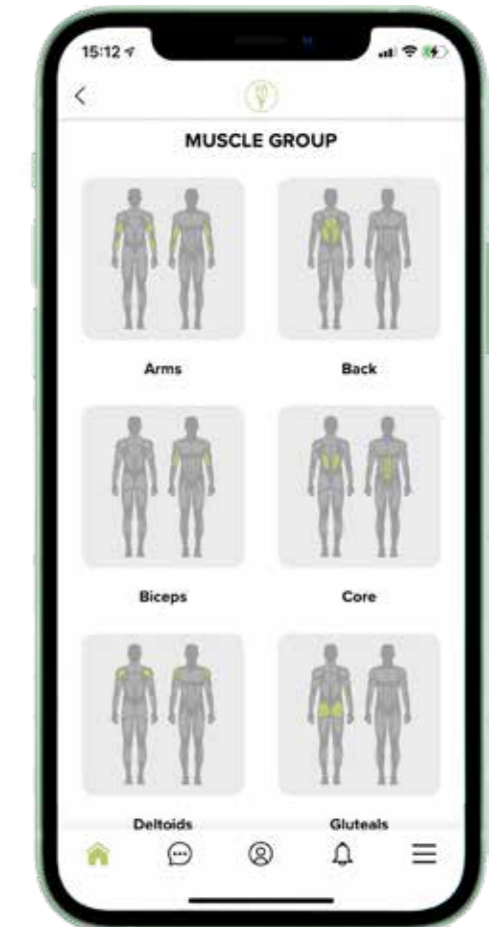

Choose the muscle group you want to train with the correct video tutorial. Create and customize your workout according to your needs.

*Scegli il gruppo muscolare che vuoi allenare con il video tutorial corretto. Crea e personalizza il tuo allenamento rispetto alle tue necessità.*



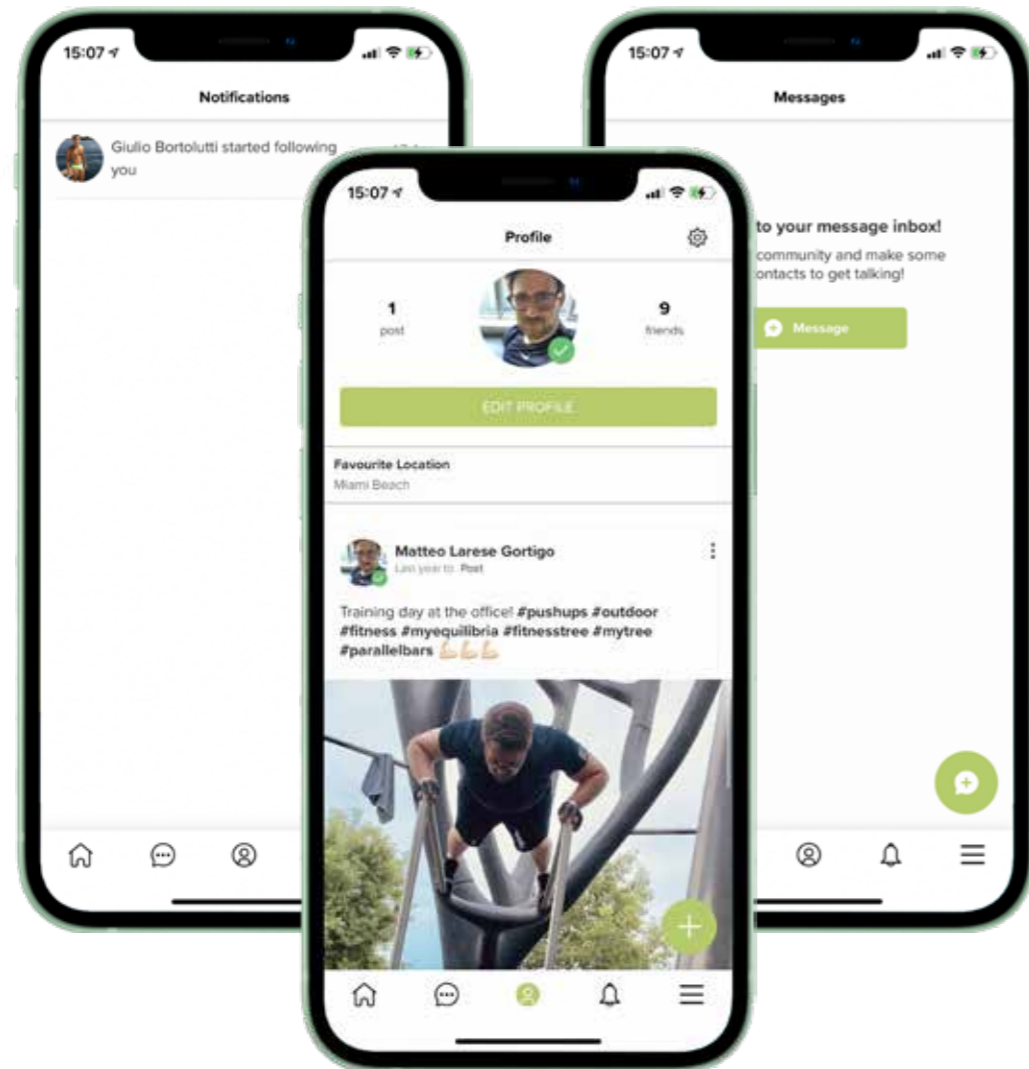

## Digital Community.

Users could register themselves, create their own personal profile and logging in the MyEquilibria digital community.

- Customized profile
- Access to the MyEquilibria digital community
- Possibility to share photos and videos from the feed, comments, likes and DMs
- follower-following available

*Gli utenti possono registrarsi, creare il proprio profilo personale ed accedere alla digital community di MyEquilibria.*

- *Personalizza il tuo profilo*
- *Accedi all'esclusiva community di MyEquilibria*
- *Possibilità di condividere foto e video dal feed, commentare, lasciare likes ed utilizzare DM.*
- *Funzione follower-following disponibile*



# The Journey.

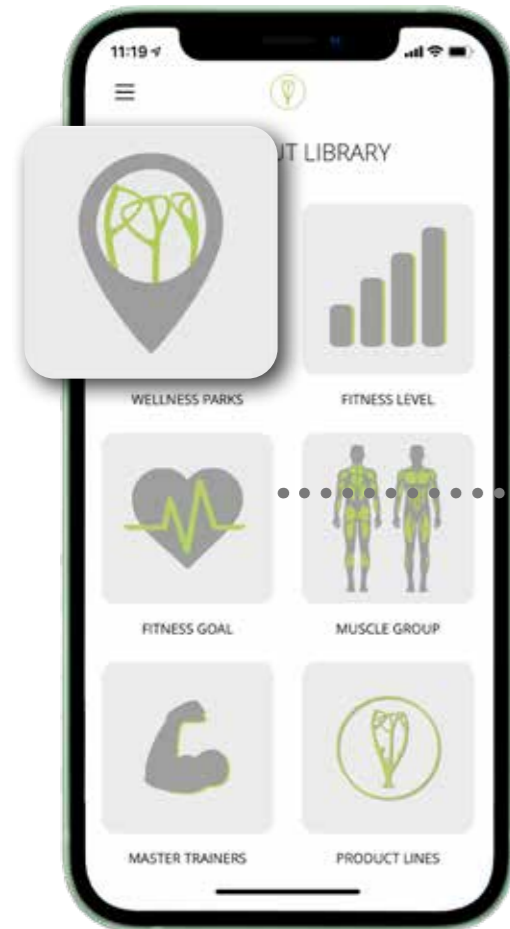

Select the Wellness Park  
*Seleziona il Parco Wellness*



Select your location  
*Seleziona la tua location*



Discover the fitness area  
*Scopri l'area fitness*

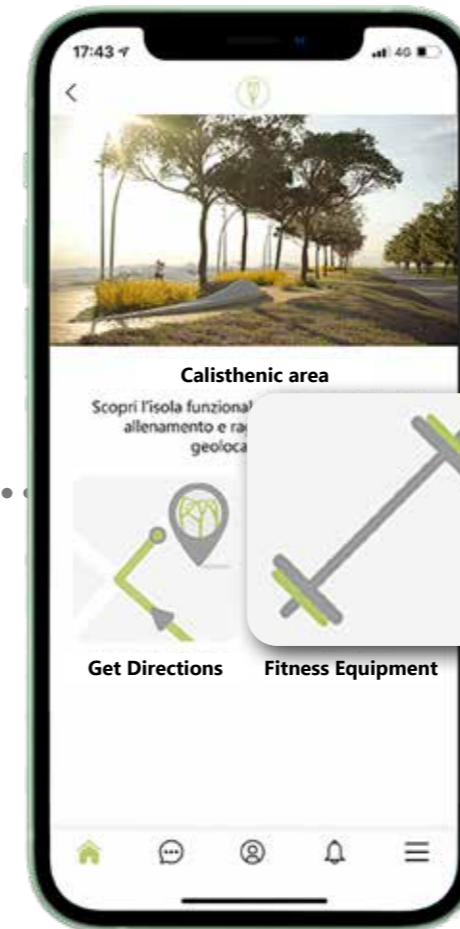

Decide whether to get directions or discover the video tutorials equipment  
*Scegli se trovare le indicazioni per il parco o scoprire i video tutorial dei prodotti*



Select your accessory  
*Seleziona il tuo accessorio*

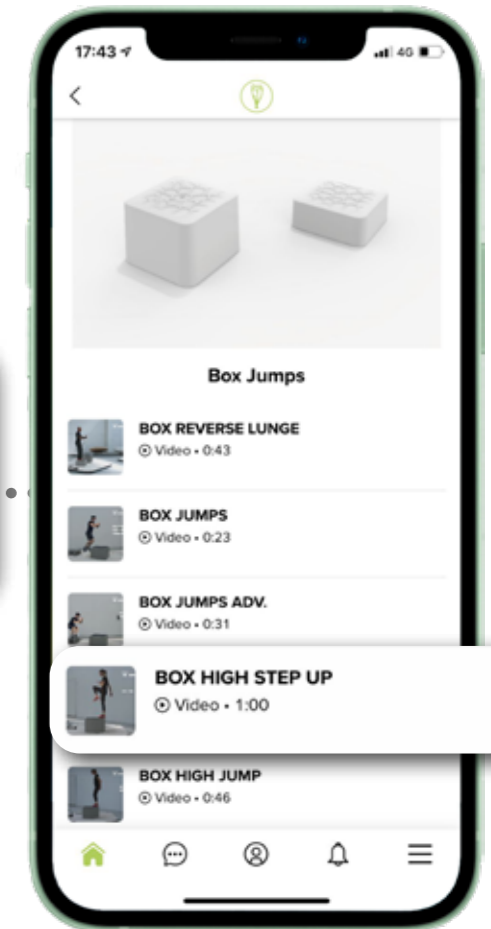

Select the exercise, watch the video tutorial and start your workout  
*Scegli l'esercizio, guarda il video tutorial e inizia il tuo workout*



## Awards & Nominations.



2016



reddot design award

2018



2017



Premio Compasso d'Oro ADI

2018



2017



BIGSEE  
PRODUCT DESIGN  
AWARD 2019  
WINNER

2019



2017







## Sale segments.

Each of our structures has been designed for different sales segments.

Unique and elegant design, innovative features and total customization allow perfect integration in every context.

*Ognuna delle nostre strutture e' stata progettata per differenti canali di vendita.*

*Design unico ed elegante, funzioni innovative, totale customizzazione che permettono un'integrazione perfetta in ogni contesto.*





## Private villas.

An undeniable benefit of living in a villa is the possibility of taking advantage of outdoor space and getting closer to nature. MyEquilibria allows you to incorporate outdoor exercise into your daily routine.

*Un innegabile beneficio dato dal vivere in villa è la possibilità di sfruttare al massimo gli spazi esterni e avvicinarsi maggiormente alla natura. MyEquilibria permette di unire l'esercizio all'aperto nella propria routine quotidiana.*



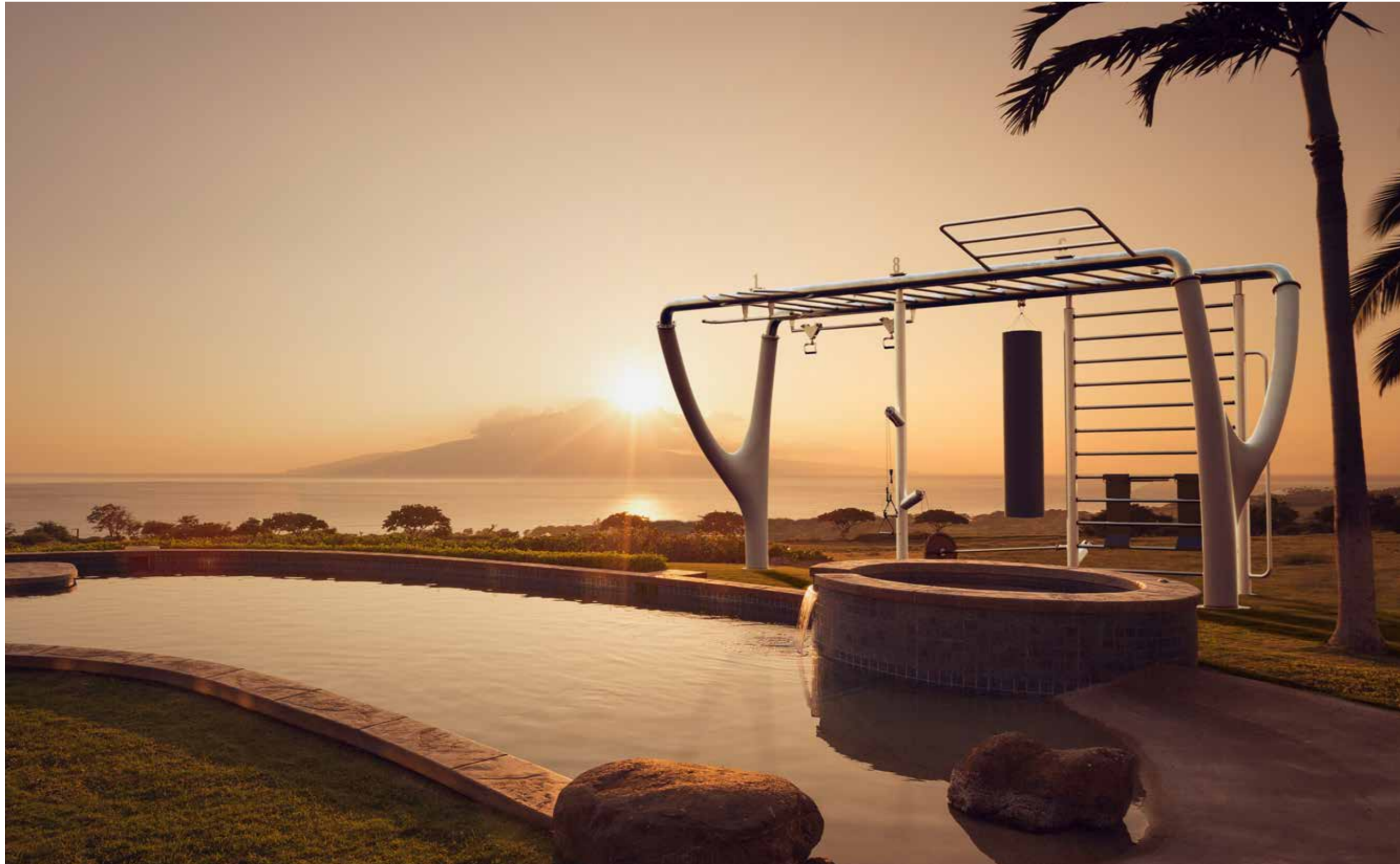

## Hospitality.

The outdoor and indoor spaces of resorts and hotels create a significant additional value for the guests. Using these spaces means embracing workouts in the open air and giving people the opportunity to enjoy a more active lifestyle, close to nature.

*Gli spazi outdoor e indoor di resort e alberghi costituiscono un valore aggiunto agli occhi degli ospiti. Utilizzare questi spazi significa condividere l'idea di allenarsi all'aria aperta, dando alle persone l'opportunità di una vita più attiva, vicino alla natura.*



## Corporate.

Employees are the core of intellectual capital in any business and their well-being has a serious and direct impact on corporate organization.

Outdoor spaces create “green” areas where employees can relax, move about and breathe a different air.

*Il capitale intellettuale di ogni azienda è costituito dalle persone che ci lavorano e il loro benessere fisico ha un effetto diretto sull'azienda.*

*Gli spazi esterni per l'allenamento creano delle aree “verdi” in cui i dipendenti hanno la possibilità di rilassarsi, muoversi e respirare un'aria diversa.*

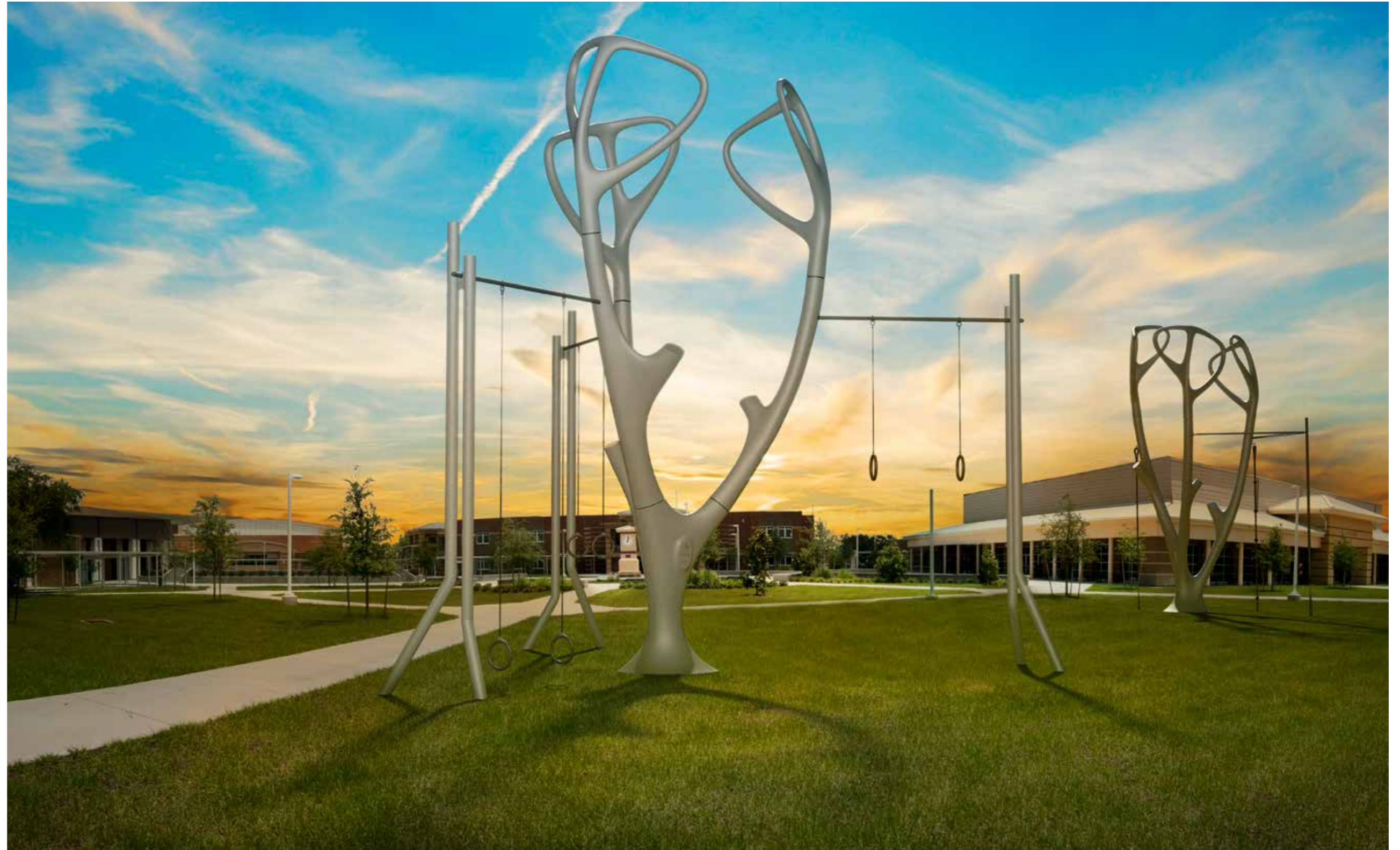





## Residential.

An outdoor wellness park would be a smart addition to any prestigious condominium. It's just a matter of choosing the best equipment to match the active lifestyle of its residents and valorize the surrounding environment.

*Uno spazio per lo sport e il wellness all'aperto rappresenta un valore strategico per qualunque struttura residenziale di prestigio. Si tratta solo di scegliere le attrezzature più vicine allo stile di vita attivo di chi vi abita e che meglio valorizzano l'ambiente circostante.*



## Public spaces.

With a quickly growing urban population, parks and green areas have become the only “breath of fresh air” from stress-charged city life.

The most progressive municipalities are actively working on enhancing public spaces with true “wellness projects for everybody”.

*Con una popolazione urbana che cresce a ritmi sostenuti, parchi e aree verdi rappresentano una “boccata d’ossigeno” nella vita frenetica delle città.*

*Le amministrazioni più virtuose stanno lavorando per riqualificare gli spazi pubblici con veri “progetti di benessere diffuso.”*





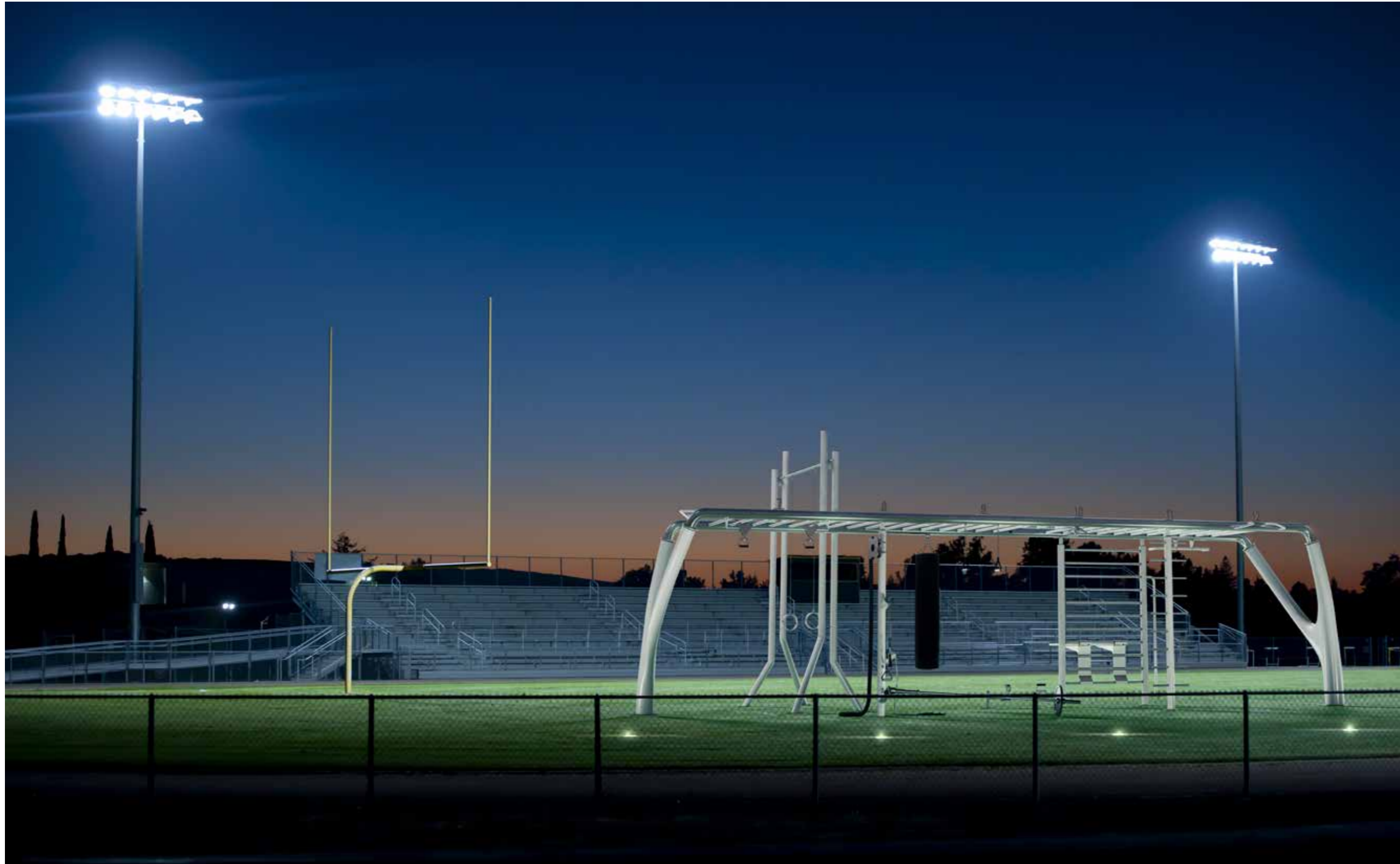

## University Campus.

University campuses are looking for new ways to incorporate popular bodyweight training into their facilities. They also want ways to optimize their investment by choosing functional installations that will look great for years to come.

*I Campus Universitari sono sempre alla ricerca di soluzioni nuove per poter includere tra i servizi offerti anche l'outdoor training. Cercano inoltre di ottimizzare gli investimenti scegliendo attrezzature funzionali, che non si degradino nel tempo.*



## Gyms.

The most important factors for sports centers and gyms when it comes to choosing fitness equipment have always been performance, innovation, scientific research and the quality of the materials.

*Performance, innovazione, ricerca scientifica e qualità dei materiali sono da sempre elementi fondamentali per la selezione delle attrezzature nelle palestre e nei centri sportivi.*









## The Placemakers Group.

The Placemakers is the biggest street furniture and outdoor fitness equipment manufacturer group in the world, exclusively committed to anticipating future trends and designing urban space, through its prestigious brands: Metalco, Bellitalia, CityDesign, MyEquilibria, Eitherland and 1984.

The Placemakers Group is the industrial partner of the Company. Thanks to the Group's 30 years of experience and the knowledge of the industry's best practices, MyEquilibria is the undisputed leader in its field.

*The Placemakers è il più grande gruppo mondiale di produttori di arredo urbano e attrezzature per il fitness outdoor, impegnato esclusivamente ad anticipare le tendenze future e a progettare lo spazio urbano, attraverso i suoi prestigiosi marchi: Metalco, Bellitalia, CityDesign, MyEquilibria e Eitherland.*

*Il Gruppo The Placemakers è il partner industriale della Società. Grazie ai 30 anni di esperienza del Gruppo e alla conoscenza delle best practice del settore, MyEquilibria è leader indiscusso nel suo settore.*





## Industrial partner.

MyEquilibria works closely with partners in “The Placemakers” Group, the world’s largest industrial outdoor urban furniture group.

In particular, the concrete sector specialist and MyEquilibria’s supplier of the raw material for its structures and accessories is Bellitalia, Europe’s leading concrete and natural stone product manufacturer.

Standing out for the quality of its materials, technological innovation and design, for more than 40 years, Bellitalia has been designing, manufacturing and supplying pioneering concrete, controlling every stage of the production process.

The recent collaboration with SIMAU (Marche Polytechnic University Department of Science and Engineering of Materials, the Environment and Urban Planning) has strengthened Bellitalia’s know-how, aware of the important role these relationships play in the technological and industrial development of the product.

This is why MyEquilibria collaborates with Bellitalia, in order to express the essence of the products as effectively as possible.

*MyEquilibria collabora a stretto contatto con i partner di “The Placemakers”, il più grande gruppo industriale al mondo per l’arredo urbano outdoor.*

*In particolare, l’azienda specializzata nel settore del cemento e che fornisce a MyEquilibria la materia prima per le strutture e gli accessori è Bellitalia: azienda leader in Europa nella produzione di manufatti in cemento e pietra naturale. Per oltre 40 anni, contraddistinta da qualità dei materiali, innovazione tecnologica e design, Bellitalia progetta, produce e fornisce cementi all’avanguardia e ultra-performanti, controllando ogni fase della lavorazione dei prodotti.*

*La recente collaborazione con SIMAU, il Dipartimento di Scienze e Ingegneria della Materia, dell’Ambiente e dell’Urbanistica dell’Università Politecnica delle Marche, ha rafforzato il know-how di Bellitalia, consapevole dell’importanza che queste relazioni hanno nello sviluppo tecnologico-industriale del prodotto.*

*Per queste ragioni MyEquilibria collabora con Bellitalia per la fornitura e la lavorazione dei cementi ultra-performanti, capaci di esprimere al meglio l’essenza dei prodotti.*







## Materials.

Only the most exclusive materials have been selected to craft MyEquilibria products and accessories.

Our ultra-high performance fiber-reinforced concrete, stainless steel, exotic woods, technical compounds used in competitive sports and breakthrough materials are engineered to withstand highly demanding outdoor environments and come in a wide range of colors and eco-friendly finishes.

- High Performance Concrete
- Ultralight Composite Material
- AISI 304 Stainless Steel
- AISI 316 Stainless Steel
- Hot deep galvanized Steel
- Aluminium

*Per realizzare i prodotti e gli accessori MyEquilibria sono stati selezionati soltanto i materiali migliori.*

*Cementi fibro-rinforzati ultraperformanti, acciaio inox, legni esotici, materiali tecnici provenienti dallo sport agonistico, materiali studiati appositamente per esterni e resistenti sempre e comunque, in tutte le condizioni atmosferiche, vengono proposti in una vasta gamma di colori e con finiture eco-compatibili.*

- *Cemento ultra performante*
- *Materiale Composito Ultraleggero*
- *AISI 304 Acciaio Inox*
- *AISI 316 Acciaio Inox*
- *Acciaio zincato a caldo*
- *Alluminio*



## High Performing Concrete

Mixture of high-performance reinforced concrete with granite or marble aggregates and good technical and structural characteristics. Aggregates are accurately selected and available in different versions (granite, white marble or black marble).

This high performance fiber-reinforced concrete providing high technical and structural performance combined with extraordinary freedom of design.

*Miscela realizzata in cemento rinforzato performante, con aggiunta di inerti di granito o marmo, con buone performance tecnico strutturali. Gli inerti vengono accuratamente selezionati e proposti in diverse versioni (granito, marmo bianco oppure marmo nero).*

*Questa miscela realizzata in cemento rinforzato fibrato ultra performante che garantisce elevate performance tecnico strutturali unite ad una straordinaria libertà progettuale*





## Steel & Aluminium.

Simple painting is not enough to prevent steel from corroding on exposure to atmospheric agents. Among the range of possible safeguarding processes, hot dip galvanization is the most reliable and long lasting and, together with industrial powder coating, represents the optimal combination for protecting steel in outdoor applications.

Stainless steel is the ultimate metallic material in terms of durability and resistance to atmospheric agents (AISI 304 and AISI 316).

We also protect the stainless steel even further with additional electropolishing and/or sandblasting treatments.

Aluminium is used to obtain light and aesthetically pleasing products with high resistance to atmospheric agents.

*Una semplice verniciatura non è abbastanza protettiva da prevenire la corrosione dell'acciaio esposto ai diversi agenti atmosferici. La zincatura a caldo è la più affidabile e duratura tra tutti i diversi processi di salvaguardia possibili e, insieme a un rivestimento in polvere industriale, rappresenta la combinazione ottimale per proteggere l'acciaio nelle applicazioni esterne.*

*L'acciaio inox rappresenta il non-plus-ultra dei materiali metallici in termini di durata e resistenza agli agenti atmosferici (AISI 304 and AISI 316). Forniamo inoltre un'ulteriore protezione all'acciaio inox, attraverso il trattamento di elettrolucidatura e/o sabbiatura.*

*L'alluminio è un materiale impiegato per ottenere prodotti leggeri, esteticamente gradevoli e con un'alta resistenza agli agenti atmosferici.*









## Safety EU & USA.

All equipment has been designed to allow safe training, in terms of fall heights and wind resistance.

To guarantee user safety, placing antishock material underneath the equipment is mandatory wherever there is a fall height risk. The thickness of the layer of antishock material depends on the nature of the material itself and on the fall height.

All our products comply with EU and US safety regulations.

*Tutte le strutture sono state progettate per l'allenamento in sicurezza, sia in termini di altezza di caduta sia per resistenza al vento. Per garantire la sicurezza agli utenti, del materiale antishock, sotto le attrezzature diventa necessario ovunque si presenti il rischio di caduta. Lo strato del materiale antishock dipende dalla natura stessa del materiale utilizzato.*

*Tutti i nostri prodotti sono conformi alle certificazioni europee e USA per la sicurezza.*

### EU

- ISO EN 20957-1: 2013
- ISO EN 16630: 2015

### USA

- ASTM F3101-15
- ASTM F2571-15







## Who we are.

Gian Luca Innocenzi has always been a lover of outdoor exercise and to show his gratitude for its benefits, he has decided to create a better world, creating sculptures inspired by nature and in respect of the principles of biomechanics.

MyEquilibria is made possible thanks to Gian Luca's 20 years of fitness experience and the even longer experience of Alfredo Tasca, CEO of Metalco, a leading urban furniture company. Their mission is to redefine the workout experience and integrate it with art, top calibre fitness equipment and the community.

MyEquilibria has been built with the "Instinctive Wellness Philosophy", a combination of body weight and gravity training so perfect that the workout becomes intuitive, fun and functional.

*Gian Luca Innocenzi è sempre stato un amante dell'esercizio fisico all'aria aperta e grazie ai benefici che lui stesso otteneva ha deciso di creare un mondo più bello installando sculture ispirate alla natura e funzionali nel rispetto della biomeccanica.*

*MyEquilibria nasce da un'esperienza 20ennale nel mondo del fitness del suo fondatore Gian Luca e l'esperienza 30ennale di Alfredo Tasca titolare di Metalco, azienda leader di arredo urbano. La loro missione era quella di ridefinire l'attività fisica mediante l'integrazione tra arte, attrezzature fitness di altissima finitura e la comunità.*

*MyEquilibria è stata costruita sulla "filosofia del wellness istintivo" che sfrutta alla perfezione la combinazione tra peso corporeo e gravità, rendendo l'attività fisica intuitiva, divertente e funzionale.*









## Offices & Distributors.

### Headquarter.

ITALY  
METALCO ACTIVE SRL  
Via della Fornace, 44  
Castelminio di Resana, TV, 31023, IT  
[www.myequilibrio.com](http://www.myequilibrio.com)  
+ 39 0423 7863  
[info@myequilibria.com](mailto:info@myequilibria.com)

### Branches.

USA  
METALCO ACTIVE USA INC.  
420 Lincoln Road, Suite 357  
Miami Beach, FL 33139  
[info@myequilibria.com](mailto:info@myequilibria.com)

### Distributors.

WORLDWIDE PRESENTS  
Further information:  
[info@myequilibria.com](mailto:info@myequilibria.com)



CONCEPT  
Matteo Larese Gortigo

PHOTO  
Urnato.it  
Jacopo Spilimbergo  
Shutterstock.com

Patents and designs owned by Metalco Active srl  
*Brevetti e design di proprietà di Metalco Active srl*

© All rights reserved  
The reproduction of images, drawings and texts, even if partial, is forbidden.

© Tutti i diritti riservati  
*E' vietata la riproduzione anche parziale di immagini e testi.*

METALCO ACTIVE SRL  
Via della Fornace, 44  
31023 Castelminio di Resana (TV) Italy

Printed in 2021  
Second Edition  
*Finito di stampare nel 2021*  
Seconda edizione

Metalco Active Srl reserves the right to modify the dimensions and structure of its products at any time without prior notice in order to improve quality and durability. Photos, drawings and text are not contractual. For possible modifications or updates, please refer to the web site.

MyEquilibria the Wellness Park, Mysle, MyBeast, are registered trademarks of Metalco Active Srl. Unparalleled Tree, Leopard Tree, Vertical Tree, Zen Tree, Rope Tree, Ring Tree and all accessories are protected by patents and designs owned by Metalco Active Srl.

For any changes or updates, refer to the website [www.myequilibria.com](http://www.myequilibria.com).

*Metalco Active Srl si riserva di apportare ai propri prodotti qualsiasi modifica ritenuta utile al miglioramento qualitativo degli stessi, sia dimensionale che strutturale. Foto, disegni e testi non hanno carattere contrattuale. Per eventuali modifiche o aggiornamenti fare riferimento al sito web.*

*MyEquilibria the Wellness Park, Mysle, MyBeast, sono marchi depositati di Metalco Active Srl. Unparalleled Tree, Leopard Tree, Vertical Tree, Zen Tree, Rope Tree, Ring Tree e tutti gli accessori sono tutelati da brevetti e design di proprietà di Metalco Active Srl.*

*Per eventuali modifiche o aggiornamenti fare riferimento al sito web [www.myequilibria.com](http://www.myequilibria.com).*











METALCO ACTIVE SRL

Via della Fornace, 44

31023 Castelminio di Resana (TV) Italy

P. IVA 09176320969

Ph. +39 0423 7863

Fax. +39 0423 786400

[www.myequilibria.com](http://www.myequilibria.com)

[info@myequilibria.com](mailto:info@myequilibria.com)

